

Medium-voltage power distribution and control systems > Switchgear >

VacClad-W 5–15 kV, 36" wide metal-clad medium-voltage switchgear

Contents

General Description	5.1-2
General Description	5.1-2
Standard Metal-Clad Switchgear Assembly Ratings	5.1-4
Devices	5.1-5
Circuit Breakers	5.1-5
Switchgear Meters	5.1-19
Protective Relays	5.1-19
Instrument Transformers	5.1-19
Ohmic Voltage Sensing (OVS)	5.1-21
Thermal Monitoring	5.1-22
Dummy Element (Dummy Breaker)	5.1-22
Roll-on-the-Floor Breaker Option	5.1-23
Integral Motorized Remote Racking Option (VCP-W MR2)	5.1-24
Accessories	5.1-28
InsulGard Partial Discharge Sensing and Monitoring	5.1-29
Layouts and Dimensions	5.1-32
Standard Height—Layouts	5.1-32
Standard Height—Dimensions in Inches (mm)	5.1-36
Low Profile—Dimensions	5.1-42
Low Profile—Layouts	5.1-42
Application Data	5.1-43
Service Conditions	5.1-43
Standard Height—Weights	5.1-44
Low Profile—Weights	5.1-44
Heat Loss	5.1-45
Control Power Requirements	5.1-45
Typical Schematics	5.1-46



EATON

Powering Business Worldwide



More about this product
Eaton.com/mva



Complete library of design guides
Eaton.com/designguides

General Description

Eaton's VacClad-W metal-clad switchgear with Type VCP-W vacuum breakers provides centralized control and protection of medium-voltage power equipment and circuits in industrial, commercial and utility installations involving generators, motors, feeder circuits, and transmission and distribution lines.

VacClad-W offers a total design concept of cell, breaker and auxiliary equipment, which can be assembled in various combinations to satisfy user application requirements. Two-high breaker arrangements are standard up to 15 kV. One-high arrangements can be furnished when required.

Ratings

Maximum Voltages:

4.76 kV, 8.25 kV, 15 kV

Interrupting Ratings:

4.76 kV: Up to 63 kA

8.25 kV: Up to 63 kA

15.0 kV: Up to 63 kA

Continuous Current—Circuit Breakers:

1200 A, 2000 A, 3000 A (5 and 15 kV)

4000 A forced cooled (5 and 15 kV)

Continuous Current—Main Bus:

1200 A, 2000 A, 3000 A (5 and 15 kV)

4000 A (5 and 15 kV)

Note: Continuous currents above 4000 A, contact Eaton.

Certifications

- UL® and CSA® listings are available for many configurations; consult Eaton

Additional VacClad-W Metal-Clad Switchgear Offerings

VacClad-W metal-clad switchgear is also available in the following designs:

- 5–15 kV arc resistant
- 5 kV 26-inch narrow width
- 27 kV
- 27 kV arc resistant
- 38 kV
- 38 kV arc resistant

Refer to the Eaton website for additional details.



VacClad-W Metal-Clad Switchgear



VCP-W Circuit Breaker

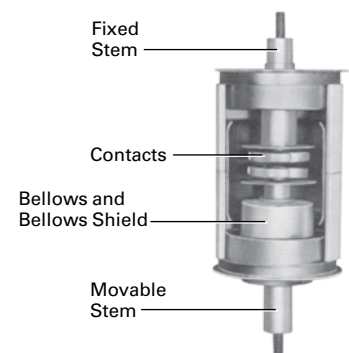

*Cut-Away View of Vacuum Interrupter
(Enlarged to Show Detail)*

Advantages

Eaton has been manufacturing metal-clad switchgear for over 60 years, and vacuum circuit breakers for more than 40 years. Tens of thousands of Eaton vacuum circuit breakers, used in a wide variety of applications, have been setting industry performance standards for years.

With reliability as a fundamental goal, Eaton engineers have simplified the VacClad-W switchgear design to minimize problems and gain trouble-free performance. Special attention was given to material quality and maximum possible use was made of components proven over the years in Eaton switchgear.

Maintenance requirements are minimized by the use of enclosed long-life vacuum interrupters. When maintenance or inspection is required, the component arrangements and drawers allow easy access. The light weight of the VacClad-W simplifies handling and relocation of the breakers.

Standards

Eaton's VacClad-W switchgear meets or exceeds ANSI/IEEE® C37.20.2 and NEMA® SG-5 as they apply to metal-clad switchgear. The assemblies also conform to Canadian standard CSA® C22.2 No. 31, and EEMAC G8-3.2. Type VCP-W vacuum circuit breakers meet or exceed all ANSI and IEEE standards applicable to ac high-voltage circuit breakers rated on symmetrical current basis.

Metal-Clad Switchgear Compartmentalization

Medium-voltage metal-clad switchgear equipment conforming to C37.20.2 is a compartmentalized design, wherein primary conductors are fully insulated for the rated maximum voltage of the assembly, and all major primary circuit components are isolated from each other by grounded metal barriers. This type of construction minimizes the likelihood of arcing faults within the equipment and propagation of fault between the compartments containing major primary circuits.

The C37.20.2 metal-clad switchgear equipment is designed to withstand the effects of short-circuit current in a bolted fault occurring immediately downstream from the load terminals of the switchgear. The bolted fault capability is verified by short-time and momentary short-circuit withstand current testing on complete switchgear, as well as by fault making (close and latch) testing on the switching devices as shown in Figure 5.1-1.

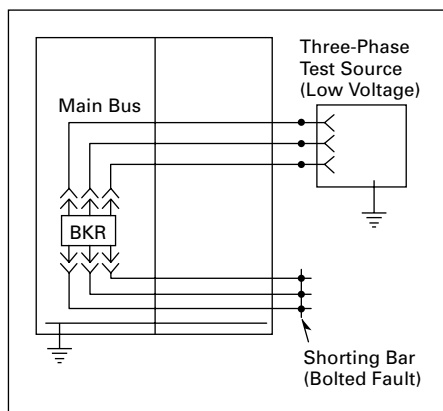

Figure 5.1-1. Metal-Clad Switchgear Short-Circuit and Momentary Withstand Tests

The short-time current withstand tests demonstrate electrical adequacy of buses and connections against physical damage while carrying the short-circuit current for a given duration. The momentary current withstand tests demonstrate the mechanical adequacy of the structure, buses and connections to withstand electro-magnetic forces with no breakage of insulation. It should be noted that design testing of standard metal-clad switchgear does not involve any internal arcing faults.

VacClad is Corona Free

Corona emissions within the standard VacClad switchgear assemblies have been eliminated or reduced to very low levels by special fabrication and assembly techniques, such as rounding and buffing of all sharp copper edges at the joints, employing star washers for bolting metal barriers, and using specially crafted standoff insulators for primary bus supports. By making switchgear assemblies corona-free, Eaton has made its standard switchgear more reliable.

Standard Metal-Clad Switchgear Assembly Ratings

VacClad-W metal-clad switchgear is available for application at voltages up to 38 kV, 50 or 60 Hz. Refer to the table below for complete list of available ratings.

Table 5.1-1. Standard VCP-W (Non-Arc-Resistant) Metal-Clad Switchgear Ratings Per IEEE C37.20.2-2015 ①②

Rated Maximum Voltage	(Ref.) Rated Voltage Range Factor K	(Ref.) Rated Short-Circuit Current I	Insulation Level		Rated Main Bus Continuous Current ③④	Rated Short-Time Short-Circuit Current Withstand (2-Second)	Rated Momentary Short-Circuit Current Withstand (10-Cycle) (167 ms)	
			Power Frequency Withstand Voltage, 60 Hz, 1 Minute	Lightning Impulse Withstand Voltage [LIWV] (BIL)			K*I ⑤	2.7 *K*I ⑥
kV rms		kA rms	kV rms	kV Peak	Amperes	kA rms Sym.	kA Crest	kA rms Asym.
4.76	1	25	19	60	1200, 2000, 3000, 4000	25	68	40
	1.24	29			1200, 2000, 3000, 4000	36	97	58
	1	40			1200, 2000, 3000, 4000	40	108	64
	1.19	41			1200, 2000, 3000, 4000	49	132	78
	1	50			1200, 2000, 3000, 4000	50	135	80
	1	63			1200, 2000, 3000, 4000	63	170	101
8.25	1.25	33	36	95	1200, 2000, 3000, 4000	41	111	66
	1	50			1200, 2000, 3000, 4000	50	135	80
15	1.3	18	36	95	1200, 2000, 3000, 4000	23	62	37
	1	25			1200, 2000, 3000, 4000	25	68	40
	1.3	28			1200, 2000, 3000, 4000	36	97	58
	1	40			1200, 2000, 3000, 4000	40	108	64
	1.3	37			1200, 2000, 3000, 4000	48	130	77
	1	50			1200, 2000, 3000, 4000	50	135	80
	1	63			1200, 2000, 3000, 4000	63	170	101
27	1	16	60	125	1200, 2000, 2500, 2700	16	43	26
	1	22			1200, 2000, 2500, 2700	22	60	35
	1	25			1200, 2000, 2500, 2700	25	68	40
	1	31.5			1200, 2000, 2500, 2700	31.5	85	51
	1	40			1200, 2000, 2500, 2700	40	108	64
38	1	16	80	150 ⑧	1200, 2000, 2500	16	43	26
	1	25			1200, 2000, 2500	25	68	40
	1	31.5			1200, 2000, 2500	31.5	85	51
	1.65	23			1200, 2000, 2500	35	95	56
	1	40			1200, 2000, 2500	40	108	64

① The switchgear assembly is designed for use with type VCP-W, VCP-WC and VCP-WG circuit breakers. However, please note that certain VCP-WC circuit breakers may have higher capabilities than required by ANSI standards. In such cases, switchgear assembly ratings as given in this table will apply.

② Switchgear assemblies can be supplied with UL®/CSA® label. Contact Eaton for availability.

③ Circuit breaker requires forced air cooling to carry 4000 A at 4.76, 8.25 and 15 kV, and 3000 A at 38 kV.

④ 27 kV 2500 A and 2700 A main bus ratings are available in two-high design configurations only.

⑤ Please note that use of certain current transformers (for example, bar type CTs) and protective devices may limit the duration to a value less than 2 seconds.

⑥ These values exceed 2.6*K*I required by IEEE C37.20.2-2015.

⑦ These values exceed 1.55*K*I required by IEEE C37.20.2-2015.

⑧ This is a standard IEEE C37.20.2 rating for 38 kV Class of switchgear.

Circuit Breakers

VCP-W Circuit Breakers

Eaton's VCP-W medium-voltage circuit breakers offer the latest in vacuum technology, providing superior control and protection of medium-voltage power equipment in utility, industrial, commercial, mining and marine installations. Built in a state-of-the-art ISO® 9002 certified facility, they meet or exceed all ANSI requirements. Available in drawout configurations, Eaton's vacuum circuit breakers are a result of our ongoing commitment to research and development, which have resulted in significant breakthrough technologies. Each breaker is provided with its unique Quality Assurance Certificate that documents all tests and inspections performed. As a continuous product quality and reliability improvement, Eaton has now introduced 5 and 15 kV VCP-W circuit breakers rated up to 50 kA with newer and simplified pole units with longer VI life. The refreshed VCP-W circuit breakers have been tested to ANSI/IEEE standards C37.04-2018 and C37.09-2018. Refer to **Table 5.1-2** for available ratings.

VCP-W Standard Features

- Eaton's maintenance-free vacuum interrupters with visual contact erosion indicator
- Non-sliding/non-rolling flexible current transfer system
- Glass polyester insulation
- Front-accessible operating mechanism
- Electrically operated trip-free, spring stored energy mechanism
- Interlocks that prevent moving a closed circuit breaker into or out of the connected position
- Closing springs automatically discharge before moving the circuit breaker into or out of the enclosure
- Provisions for manual charging of closing springs
- Manual close and trip pushbuttons
- Operations counter
- Closing spring charged/discharged indicator
- Circuit breaker Open/Closed indicator
- Auxiliary switch with 2A/3B for dc and 1A/3B for ac spare contacts
- Spring charging motor, close coil, trip coil, latch check switch and anti-pump relay

VCP-W Circuit Breaker Ratings

- **Table 5.1-2** includes 5/15 kV circuit breakers rated on the basis of $K = 1.0$ in accordance with ANSI standards for 25 kA, 40 kA and 50 kA at 60 Hz
- **Table 5.1-3** includes 5/15 kV circuit breakers rated on the basis of $K = 1.0$ in accordance with ANSI standards for 63 kA at 60 Hz and 25 kA, 40 kA, 50 kA and 63 kA at 50 Hz
- **Table 5.1-4** includes capabilities of traditional 5/15 kV circuit breakers rated on the basis of $K > 1.0$. Contact Eaton for availability of these circuit breakers

The following discussion provides a brief explanation of rated voltage range factor $K = 1$ and $K > 1.0$.

Discussion of changes in the Rated Voltage Range Factor, K, or "K-factor"

In 1997 and 2000 editions of ANSI C37.06, under Table 1, preferred values for the rated voltage range factor, K , were set to 1.0 for all indoor circuit breaker ratings. This was done because interrupting capabilities of today's vacuum circuit breakers are better represented by $K = 1.0$.

Unlike old air-magnetic and oil circuit breakers, today's vacuum breakers generally do not require a reduction in interrupting current, as the operating voltage is raised to rated maximum voltage, for example from 11.5 kV up to 15 kV. The interrupting capability of vacuum circuit breakers is essentially constant over the entire range of operating voltages, up to and including its rated maximum voltage.

The change was also made as a step toward harmonizing preferred ANSI ratings with the preferred ratings of IEC standards. It was further recognized that it is much simpler to select and apply circuit breakers rated on the basis of $K = 1.0$.

The change in the K value, however, in no way affects the ratings and capabilities of circuit breakers originally tested and rated on the basis of $K > 1$ in the earlier editions of C37.06. Existing circuit breakers, with ratings based on $K > 1.0$, are still perfectly valid, meet the latest editions of the standards, and should be continued to be applied as they have been in the past. The original $K > 1.0$ ratings are neither "obsolete" nor "inferior" to the new $K = 1.0$ ratings; they are just different.

The new 1997 and 2000 editions of ANSI standard C37.06 still include the earlier $K > 1$ ratings as Table A1 and A1A. The change from $K > 1.0$ to $K = 1.0$ should be implemented by manufacturers as they develop and test new circuit breaker designs. The change does not require, recommend or suggest that manufactures re-rate and re-test existing breakers to new standard.

And accordingly, Eaton continues to offer both circuit breakers rated on the traditional basis of $K > 1.0$ just as thousands of those breakers have been applied for variety of circuit switching applications worldwide, and also as Eaton develops new breakers, they are rated and tested to the new $K = 1$ ratings.

As a leader in vacuum interruption technology, Eaton continues to provide a wide choice of modern vacuum circuit breakers so that the user can select the most economical circuit breaker that can satisfy their circuit switching application.



VCP-W Breaker (Side View)

**Table 5.1-2. 5/15 kV VCP-W Vacuum Circuit Breakers Rated on Symmetrical Current Rating Basis, Per IEEE C37.04-2018 and C37.09-2018 Standards, (Rated K=1)
(Continued on Next Page)**

Identification Drawout Circuit Breaker Type	Rated Values ①					Short-Circuit Ratings (Reference C37.04-2018 and C37.09-2018)							Transient Recovery Voltage			
	Maximum Voltage (V)	Frequency ②	Insulation Level		Continuous Current at 60 Hz	Symmetrical Interrupting Current (I) ④	DC Component ⑤	Asymmetrical Interrupting Current (I _t) ⑦	Closing and Latching Current (= 2.6 x K x I)	Short-Time Withstand Current ⑧	Interrupting Time	Interrupting Time (Cycles at 60 Hz)	Peak Voltage (E ₂) = (u _c)	Time to Peak T ₂ = t ₃ x 1.137	TRV Rise Time (t _r)	RRRV = u _c /t _r
Power Frequency Withstand Voltage (1 min.)			Lightning Impulse Withstand Voltage (1.2 x 50 μs)	kV rms												
5VCP-W25	4.76	60	19	60	1200 2000 3000 ③	25	43	29	65	25	50	3	8	50	44	0.19
5VCP-W40	4.76	60	19	60	1200 2000 3000 ③	40	43	47	104	40	50	3	8	50	44	0.19
5VCP-W50	4.76	60	19	60	1200 2000 3000 ③	50	43	58.5	130	50	50	3	8	50	44	0.19
15VCP-W25	15	60	36	95	1200 2000 3000 ③	25	43	29	65	25	50	3	25.7	75	66	0.39
15VCP-W40	15	60	36	95	1200 2000 3000 ③	40	43	47	104	40	50	3	25.7	75	66	0.39
15VCP-W50	15	60	36	95	1200 2000 3000 ③	50	43	58.5	130	50	50	3	25.7	75	66	0.39

① All breakers listed in this chart are also UL Listed.

② All circuit breakers in this chart are tested at 60 Hz. They cannot be applied at 50 Hz. For 50 Hz application, refer to circuit breakers that are listed in **Table 5.1-3, Table 5.1-4, Table 5.1-7, Table 5.1-8 and Table 5.1-9** as desired.

③ 3000 A rated circuit breaker can be used in a 4000 A fan-cooled application. Contact Eaton for details.

④ For 63 kA rms symmetrical interrupting rating, select circuit breaker from **Table 5.1-3, Table 5.1-7, Table 5.1-8 and Table 5.1-9** as desired.

⑤ Based on the standard dc time constant of 45 ms (corresponding to X/R of 17 for 60 Hz) and minimum contact parting time of 38 ms (minimum opening time of 30 ms plus the assumed minimum relay time of 8 ms).

⑥ All breakers tested to C37.09-2018 meet the requirements for the last pole to clear during asymmetrical T100a tests defined by **Table 5.1-3**, and can safely be applied at the rated asymmetrical interrupting current.

⑦ The asymmetrical interrupting current, I_t total, is given by $I_t = I \times \text{Sqrt} [1 + 2 \times (\%dc/100) \times (\%dc/100)]$ kA rms asymmetrical.

⑧ Duration of short-time current and maximum permissible tripping delay are both 2 seconds for all circuit breakers listed in this table, as required in C37.04-2018 and C37.09-2018.

Table 5.1-2. 5/15 kV VCP-W Vacuum Circuit Breakers Rated on Symmetrical Current Rating Basis, Per IEEE C37.04-2018 and C37.09-2018 Standards, (Rated K=1) (Continued)

Identification	Rated Values													
	Drawout Circuit Breaker Type	Continuous Current	Operating Duty [Ⓢ]	Number Of No-Load Operations (Mechanical Endurance, Class M2)	Capacitance Current Switching Capabilities								Out of Phase Switching	
					Cable-Charging Current		Isolated Shunt Capacitor Bank Current		Back To Back Capacitor Bank				Voltage = 1.44 x V	Current = 0.25 x I
Units	A rms	Duty Cycle	Ⓢ	Class	A rms	Class	A rms	Class	A rms	kA peak	kHz	kV rms		
5VCP-W25	1200 2000 3000	O–0.3s–CO–3m–CO	10,000	C2	3–10	C2	75–630 75–1000 75–1600	C2	75–630 75–1000 75–1600	6	0.8 0.5 0.3	7	6.3	
5VCP-W40	1200 2000 3000	O–0.3s–CO–3m–CO	10,000	C2	3–10	C2	75–630 75–1000 75–1600	C2	75–630 75–1000 75–1600	6	0.8 0.5 0.3	7	10	
5VCP-W50	1200 2000 3000	O–0.3s–CO–3m–CO	10,000	C2	3–10	C2	75–630 75–1000 75–1600	C2	75–630 75–1000 75–1600	6	0.8 0.5 0.3	7	12.5	
15VCP-W25	1200 2000 3000	O–0.3s–CO–3m–CO	10,000	C2	7.5–25	C2	75–630 75–1000 75–1600	C2	75–630 75–1000 75–1600	6	0.8 0.5 0.3	22	6.3	
15VCP-W40	1200 2000 3000	O–0.3s–CO–3m–CO	10,000	C2	7.5–25	C2	75–630 75–1000 75–1600	C2	75–630 75–1000 75–1600	6	0.8 0.5 0.3	22	10	
15VCP-W50	1200 2000 3000	O–0.3s–CO–3m–CO	10,000	C2	7.5–25	C2	75–630 75–1000 75–1600	C2	75–630 75–1000 75–1600	6	0.8 0.5 0.3	22	12.5	

Ⓢ For reclosing service, there is no derating necessary for Eaton's VCP-W family of circuit breakers. R = 100 %. Type VCP-W breaker can perform the O-C-O per IEEE C37.09; O-0.3s-CO-15s-CO per IEC 56; and some VCP-Ws have performed O-0.3s-CO-15s-CO-15s-CO-15s-CO; all with no derating. Contact Eaton for special reclosing requirements.

Ⓢ Each operation consists of one closing plus one opening.

Table 5.1-3. Available 5/15 kV VCP-W Vacuum Circuit Breaker Types Rated on Symmetrical Current Rating Basis, Per ANSI Standards Dated 2009 or Prior (Rated K = 1.0) (Continued on Next Page)

Identification Drawout Circuit Breaker Type	Rated Values															
	Maximum Voltage (V)	Power Frequency ①	Insulation Level		Continuous Current	Short-Circuit Ratings (Reference C37.04-1999 and C37.06-2009 Except as Noted ①)						Transient Recovery Voltage Parameters are Based on TD-4				Interrupting Time
			Power Frequency Withstand Voltage (1 min.)	Lightning Impulse Withstand Voltage (1.2 x 50 μs)		Symmetrical Interrupting Current (I) ③	dc Component (%dc) ④	Asymmetrical Interrupting Current (I _t) ⑤	Closing and Latching Current (2.6 x I)	Short-Time Withstand Current ⑥	Peak Voltage (E ₂) = (u _c)	Time to Peak (T ₂ = t ₃ x 1.137)	TRV Rise Time (t _r)	RRRV = u _c /t _r ⑦		
Units	kV rms	Hz	kV rms	kV Peak	A rms	kA rms sym	%	kA rms asym Total	kA Peak	rms	kV Peak	μsec	μsec	kV/μsec	ms	Cycles (60 Hz)
50VCP-W 25	4.76	60	19	60	1200 2000 3000 ②	25	50	31	65	25	8.2	50	44	0.19	50	3
50VCP-W 40	4.76	60	19	60	1200 2000 3000 ②	40	50	49	104	40	8.2	50	44	0.19	50	3
50VCP-W 50	4.76	60	19	60	1200 2000 3000 ②	50	44	59	130	50	8.2	50	44	0.19	50	3
50VCP-W 63	4.76	60	19	60	1200 2000 3000 ②	63	55	80	164	63	8.2	50	44	0.19	50	3
150VCP-W 25	15	60	36	95	1200 ⑧ 2000 3000 ②	25	50	31	65	25	28 ⑧ 25.7	75	66	0.42 0.39	50	3
150VCP-W 40	15	60	36	95	1200 2000 3000 ②	40	50	49	104	40	25.7	75	66	0.39	50	3
150VCP-W 50	15	60	36	95	1200 2000 3000 ②	50	44	59	130	50	25.7	75	66	0.39	50	3
150VCP-W 63	15	60	36	95	1200 ⑧ 2000 ⑧ 3000 ②⑧	63	55	80	164	63	28 ⑧	75	66	0.42	50	3

① All circuit breakers are tested at 60 Hz; however, they can also be applied at 50 Hz with no derating.

② 4000 A fan-cooled rating is available for 3000 A circuit breakers.

③ Because the voltage range factor K = 1, the short-time withstand current and the maximum symmetrical interrupting current are equal to the rated symmetrical interrupting current.

④ Based on the standard dc time constant of 45 ms (corresponding to X/R of 17 for 60 Hz) and the minimum contact parting time as determined from the minimum opening time plus the assumed minimum relay time of 1/2 cycle (8.33 ms for 60 Hz).

⑤ The asymmetrical interrupting current, I_t total, is given by (I_t) = I x Sqrt (1 + 2 x %dc x %dc) kA rms asymmetrical total.

⑥ Duration of short-time current and maximum permissible tripping delay are both 2 seconds for all circuit breakers listed in this table, as required in C37.04-1999, C37.06-2000 and C37.06-2009.

⑦ RRRV can also be calculated as = 1.137 x E₂/T₂.

⑧ These circuit breakers were tested to the preferred TRV ratings specified in C37.06-2000.

Table 5.1-3. Available VCP-W Vacuum Circuit Breaker Types Rated on Symmetrical Current Rating Basis, Per ANSI Standards Dated 2009 or Prior (Rated K = 1.0) (Continued)

Identification	Rated Values												
	Continuous Current	Operating Duty	Mechanical Endurance	Capacitance Current Switching Capability (Reference C37.04a-2003, C37.06-2009 and C37.09a-2005)								Out-of-Phase Switching	
				Cable-Charging Current		Isolated Shunt Capacitor Bank Current		Back-to-Back Capacitor Switching				Voltage = 1.44 x V	Current = 0.25 x I
Units	A rms	Duty Cycle	No-Load Operations ⑤⑥	Class	A rms	Class	A rms	Class	A rms	kA Peak	kHz		
50VCP-W 25	1200 2000 3000	O–0.3s–CO–3m–CO	10,000	C2	3–10	C2	75–630 75–1000 75–1600	C2	75–630 75–1000 75–1600	6	0.8 0.5 0.3	7	6.3
50VCP-W 40	1200 2000 3000	O–0.3s–CO–3m–CO	10,000	C2	3–10	C2	75–630 75–1000 75–1600	C2	75–630 75–1000 75–1600	6	0.8 0.5 0.3	7	10
50VCP-W 50	1200 2000 3000	O–0.3s–CO–3m–CO	10,000	C2	3–10	C2	75–630 75–1000 75–1600	C2	75–630 75–1000 75–1600	6	0.8 0.5 0.3	7	12.5
50VCP-W 63	1200 2000 3000	O–0.3s–CO–3m–CO	10,000	C2	7.5–25	C2	75–630 75–1000 75–1600	C2	75–630 75–1000 75–1600	6	0.8 0.5 0.3	7	15.8
150VCP-W 25	1200 2000 3000	O–0.3s–CO–3m–CO	10,000	C2	7.5–25	C2 C2 C1	75–630 75–1000 75–1600	C2 C2 C1	75–630 75–1000 75–1600	6	0.8 0.5 0.3	22	6.3
150VCP-W 40	1200 2000 3000	O–0.3s–CO–3m–CO	10,000	C2	7.5–25	C2 C2 C1	75–630 75–1000 75–1600	C2 C2 C1	75–630 75–1000 75–1600	6	0.8 0.5 0.3	22	10
150VCP-W 50	1200 2000 3000	O–0.3s–CO–3m–CO	10,000	C2	7.5–25	C2 C2 C1	75–630 75–1000 75–1600	C2 C2 C1	75–630 75–1000 75–1600	6	0.8 0.5 0.3	22	12.5
150VCP-W 63	1200 2000 3000	O–0.3s–CO–3m–CO	10,000	C2	7.5–25	C2	75–630 75–1000 75–1600	C2	75–630 75–1000 75–1600	6	0.8 0.5 0.3	22	15.8

⑤ Each operation consists of one closing plus one opening.

⑥ All 40 and 50 kA circuit breakers exceed required 5000 no-load operations; all 63 kA circuit breakers exceed the required 2000 no-load ANSI operations.

Table 5.1-4. Available 5/15 kV VCP-W Vacuum Circuit Breaker Types Rated on Symmetrical Current Rating Basis, Per ANSI Standards (Rated K > 1) ①②③④

Identification			Rated Values										Related Required Capabilities					Asymmetry Factor for VCP-W Breakers		
Circuit Breaker Type	Nominal Voltage Class	Nominal 3-Phase MVA Class	Voltage		Insulation Level		Current		Rated Transient Recovery Voltage		Rated Permissible Tripping Delay	Rated Reclosing Time	Rated Maximum Voltage Divided by K	Current Values						
			Rated Maximum Voltage	Rated Voltage Range Factor	Power Frequency Withstand Voltage (1 min.)	Lightning Impulse Withstand Voltage (1.2 x 50 μs)	Rated Continuous Current at 60 Hz	Rated Short-Circuit Current (at Rated Maximum kV)	Rated Crest Voltage	Rated Time to Crest				Rate of Rise of Recovery Voltage ⑦	Rated Interrupting Time	Maximum Sym. Interrupting Capability	3-Second Short-Time Current Carrying Capability		Closing and Latching Capability (Momentary) ⑧	
kV Class	MVA Class	V rms	K ⑤	kV rms	kV Crest	Amp	I ⑥ kA rms	E2 kV Crest	T2 μS	kV/μS	⑧ Cycles	Y ⑨ Sec.	⑩ ms	V/K kV rms	KI kA rms	KI kA rms	2.7 K Times Rated Short-Circuit Current ④		1.6 K Times Rated Short-Circuit Current	
50VCP-WND 250	4.16	250	4.76	1.24	19	60	1200	29	8.9	50	0.2	5	2	300	3.85	36	36	97	58	1.2
50VCP-W 250	4.16	250	4.76	1.24	19	60	1200 2000 3000 ⑤	29	8.9	50	0.2	5	2	300	3.85	36	36	97	58	1.2
50VCP-W 350	4.16	350	4.76	1.19	19	60	1200 2000 3000 ⑤	41	8.9	50	0.2	5	2	300	4.0	49	49	132	78	1.2
75VCP-W 500	7.2	500	8.25	1.25	36	95	1200 2000 3000 ⑤	33	15.5	60	0.29	5	2	300	6.6	41	41	111	66	1.2
150VCP-W 500	13.8	500	15	1.30	36	95	1200 2000 3000 ⑤	18	28	75	0.42	5	2	300	11.5	23	23	62	37	1.2
150VCP-W 750	13.8	750	15	1.30	36	95	1200 2000 3000 ⑤	28	28	75	0.42	5	2	300	11.5	36	36	97	58	1.2
150VCP-W 1000	13.8	1000	15	1.30	36	95	1200 2000 3000 ⑤	37	28	75	0.42	5	2	300	11.5	48	48	130	77	1.2

① For capacitor switching, refer to **Table 5.1-3** and **Table 5.1-5**.
 ② 5 and 15 kV circuit breakers are UL listed.
 ③ Circuit breakers shown in this table were tested in accordance with IEEE standard C37.09-1979.
 ④ Contact Eaton for availability of these circuit breakers.
 ⑤ For three-phase and line-to-line faults, the symmetrical interrupting capability at an operating voltage

$$I_{sc} = \frac{V}{V_o} \text{ (Rated Short-Circuit Current)}$$
But not to exceed KI.
 Single line-to-ground fault capability at an operating voltage

$$I_{sc} = 1.15 \frac{V}{V_o} \text{ (Rated Short-Circuit Current)}$$
But not to exceed KI.
 The above apply on predominately inductive or resistive three-phase circuits with normal-frequency line-to-line recovery voltage equal to the operating voltage.
 ⑥ 4000 A forced cooled rating is available for 5/15 kV. 3000 A forced cooled rating is available for 38 kV. Contact Eaton for details.

⑦ 3-cycle rating available, refer to **Table 5.1-3** and **Table 5.1-5**.
 ⑧ Tripping may be delayed beyond the rated permissible tripping delay at lower values of current in accordance with the following formula:

$$T \text{ (seconds)} = Y \left(\frac{(K \text{ Times Rated Short-Circuit Current})^2}{\text{Short-Circuit Current Through Breaker}} \right)$$

The aggregate tripping delay on all operations within any 30-minute period must not exceed the time obtained from the above formula.

⑨ For reclosing service, there is **No derating** necessary for Eaton's VCP-W family of circuit breakers. **R = 100%**. Type VCP-W breaker can perform the O-C-O per ANSI C37.09; O-0.3s-CO-15s-CO per IEC 56; and some VCP-Ws have performed O-0.3s-CO-15s-CO-15s-CO-15s-CO; **all with no derating**. Contact Eaton for special reclosing requirements.
 ⑩ For higher close and latch ratings, refer to **Table 5.1-5**.
 ⑪ Included for reference only.
 ⑫ Asymmetrical interrupting capability = "S" times symmetrical interrupting capability, both at specified operating voltage.

⑦ $RRRV = 1.137 \frac{E_2}{T_2}$

VCP-W Circuit Breaker Operating Times

The closing time (initiation of close signal to contact make) and opening time (initiation of the trip signal to contact break) are shown in **Table 5.1-5**.

Figure 5.1-2 below shows the sequence of events in the course of circuit interruption, along with applicable VCP-W circuit breaker timings.

Table 5.1-5. Closing Time and Opening Time

Rated Control Voltage	Breaker Rating	Closing Time Milliseconds	Opening Time Milliseconds	
			Standard 5-Cycle Breaker	Optional 3-Cycle Breaker
48V, 125V, 250Vdc	All	45–60	30–45	30–38
120V, 240Vac	All	45–60	—	—
120V or 240Vac capacitor trip	All	—	26–41	26–38
Optional—undervoltage trip release 48V, 125V, 250Vdc	All	—	30–45	30–45

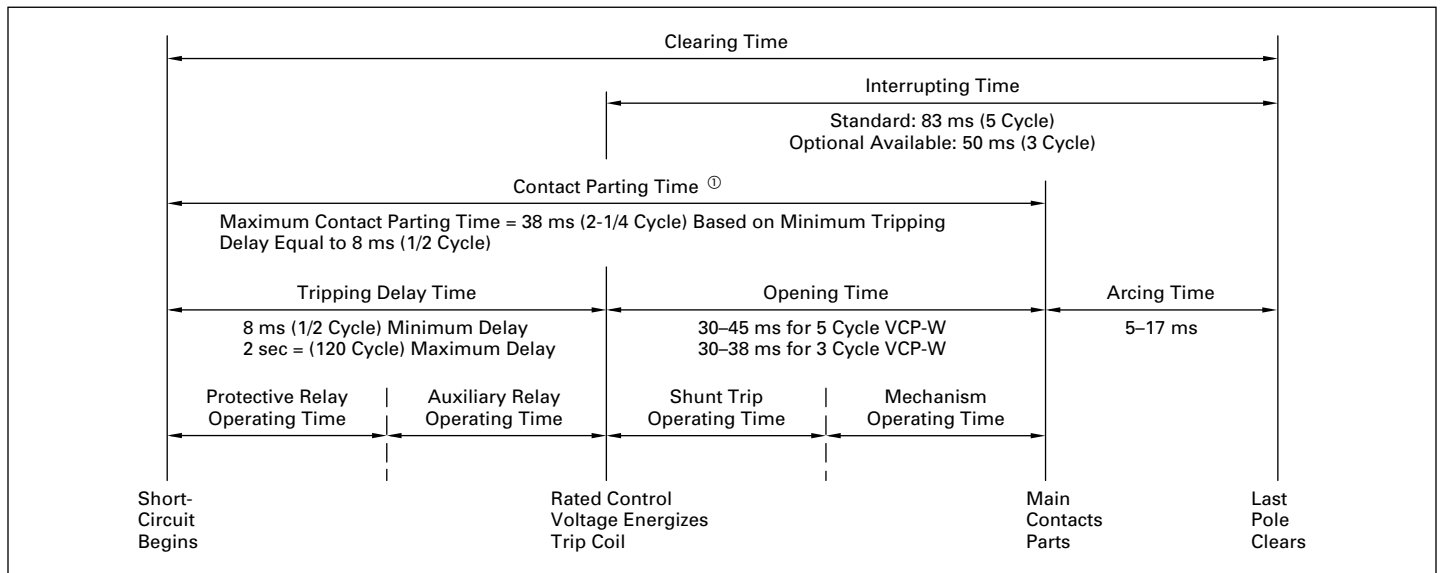

Figure 5.1-2. Sequence of Events and Circuit Breaker Operating Times

① Times shown are based on 60 Hz.

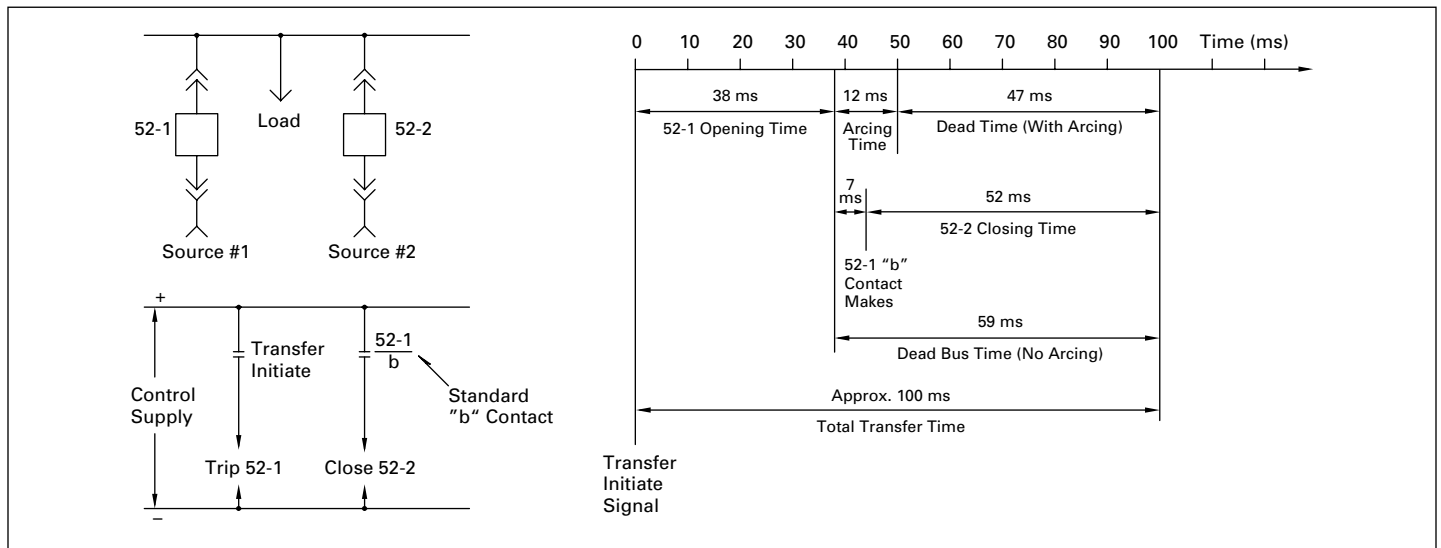

Figure 5.1-3. Typical Transfer Times ②—Fast Sequential Transfer

② Times shown are based on 60 Hz.

VCP-W Load Current Switching

Table 5.1-6 showing number of operations is a guide to normal maintenance for circuit breakers operated under usual service conditions for most repetitive duty applications including isolated capacitor bank switching and shunt reactor switching, but not for arc furnace switching. The numbers in the table are equal to or in excess of those required by ANSI C37.04/C37.06.

Maintenance shall consist of adjusting, cleaning, lubricating, tightening, etc., as recommended by the circuit breaker instruction book.

Continuous current switching assumes opening and closing rated continuous current at rated maximum voltage with power factor between 80% leading and 80% lagging.

Inrush current switching ensures a closing current equal to 600% of rated continuous current at rated maximum voltage with power factor of 30% lagging or less, and an opening current equal to rated continuous current at rated maximum voltage with power factor between 80% leading and 80% lagging.

In accordance with ANSI C37.04/C37.06, if a short-circuit operation occurs before the completion of the listed switching operations, maintenance is recommended and possible functional part replacement may be necessary, depending on previous accumulated duty, fault magnitude and expected future operations.

VCP-WC Extra Capabilities Breakers

Introducing the VCP-WC extra capability medium-voltage drawout circuit breaker. Designed to provide all the industry-leading features expected of the VCP-W, plus extra capabilities for those application requirements that go beyond what is usually experienced. The performance enhancement features of the VCP-WC make it an ideal choice for capacitor switching duty, high altitude applications, transformer secondary fault protection, locations with concentrations of rotating machinery or high operating endurance requirements, just to mention a few. Consider these capability enhancements:

- Definite purpose capacitor switching
- Higher close and latch
- Faster rate of rise of recovery voltage
- Higher short-circuit current
- Higher mechanical endurance
- Higher insulation level
- Higher voltage ratings with K=1
- 3-cycle interrupting time
- Higher switching life
- Designed and tested to ANSI standards and higher
- WR fixed retrofit configuration available

Eaton is a world leader in vacuum interrupter and vacuum circuit breaker technology, offering VCP-WC with extra capabilities without sacrificing the proven features already standard with other VCP-W circuit breakers. Features such as:

- Vacuum interrupters with copper-chrome contacts
- Flexible non-sliding current transfer system
- Visible contact erosion indicators
- Visible contact wipe indicators
- Front, functionally grouped controls and indicators
- Glass-polyester (5/15 kV), or epoxy insulation (27/38 kV)
- Front, vertically mounted stored energy mechanism
- Drawout on extension rails
- Integrally mounted wheels
- Quality Assurance Certificate

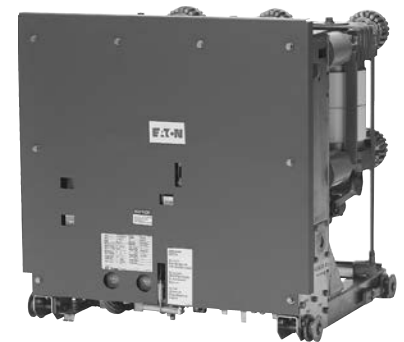

The Type VCP-WC Breakers are not Interchangeable with Standard VCP-W Breakers. They are Equipped with Different Code Plates and Taller Front Panels.

Table 5.1-6. Breaker Operations Information

Circuit Breaker Ratings			Maximum Number of Operations ①			
Rated Maximum Voltage kV rms	Rated Continuous Current Amperes	Rated Short-Circuit Current kA rms, sym.	Between Servicing	No-Load Mechanical ②	Rated Continuous Current Switching	Inrush Current Switching
4.76, 8.25, 15	1200, 2000	33 kA and below	2000	10,000	10,000	750
4.76, 8.25, 15	3000	All	1000	10,000	10,000	400
4.76, 15	All	37 kA and above	1000	10,000	10,000	400
27	All	All	500	2500	2500	100
38	All	All	250	1500	1500	100

① Each operation is comprised of one closing plus one opening.

② Unless stated otherwise in applicable circuit breaker rating table.

Table 5.1-7. Extra Capability Type VCP-WC Ratings (Symmetrical Current Basis), Rated K = 1

Identification Circuit Breaker Type	Rated Values															Mechanical Endurance Load Operations			
	Voltage		Insulation Level		Continuous Current at 60 Hz	Current						Maximum Permissible Tripping Delay	Rate of Rise of Recovery Voltage (RRRV) ^②	Capacitor Switching Ratings					
	Maximum Voltage (V)	Voltage Range Factor	Power Frequency Withstand Voltage (1 min.)	Lightning Impulse Withstand Voltage (1.2 x 50 µs)		Short-Circuit Current								General Purpose	Definite Purpose				
						Sym. Interrupting at Voltage (Isc)	% dc Component (Idc)	Asym. Interrupting (It)	Closing and Latching Capability	Short-Time Current for 3 Seconds	Interrupting Time ^①				Isolated Shunt Capacitor Bank Current		Back-to-Back Capacitor Switching		
	kV rms	K	kV rms	kV Peak	A rms							kA rms Total	%	kA rms			kA Peak	kA rms	ms
50VCP-W 25C	5.95	1	24	75	1200 2000 3000 ^③	25	50 75 75	31 36 36	97	25	50	2.0	0.9 0.9 0.8	400 & 630 1000 250	400 & 630 1000 —	20 & 20 18 —	6.5 & 5.5 2.7 —	10,000 10,000 5,000	
50VCP-W 40C	5.95	1	24	75	1200 2000 3000 ^③	40	75	58	139	40	50	2.0	0.9 0.9 0.8	630 1000 250	630 1000 —	15 18 —	3.5 2.7 —	10,000 10,000 5,000	
50VCP-W 50C	5.95	1	24	75	1200 2000 3000 ^③	50	57 57 52	64 64 62	139	50	50	2.0	0.9 0.9 0.8	630 1000 250	630 1000 —	15 18 —	3.5 2.7 —	10,000 10,000 5,000	
50VCP-W 63C	5.95	1	24	75	1200 2000 3000 ^③	63	62	83	175	63	50	2.0	1.1	250	400 & 1600 ^④ 400 & 1600 ^④ 400 & 1600 ^④	8.8 & 7.7 8.8 & 7.7 8.8 & 7.7	1.6 & 0.465 1.6 & 0.465 1.6 & 0.465	10,000 10,000 10,000	
75VCP-W 50C	10.3	1	42	95	1200 2000 3000 ^③	50	57 57 52	64 64 62	139	50	50	2.0	0.9 0.9 0.8	630 1000 250	630 1000 —	15 18 —	3.5 2.7 —	10,000 10,000 5,000	
150VCP-W 25C	17.5	1	42	95	1200 2000 3000 ^③	25	50 75 75	31 36 36	97 ^⑤	25	50	2.0	0.9 0.9 0.8	400 & 600 ^④ 1000 ^⑥ 250 ^⑥	400 & 600 ^⑥ 1000 ^⑥ —	20 & 20 18 —	6.5 & 5.5 2.7 —	10,000 10,000 5,000	
150VCP-W 40C	17.5	1	42	95	1200 2000 3000 ^③	40	75	58	139	40	50	2.0	0.9 0.9 0.8	630 ^⑥ 1000 ^⑥ 250 ^⑥	630 ^⑥ 1000 ^⑥ —	15 18 —	3.5 2.7 —	10,000 10,000 5,000	
150VCP-W 50C	17.5	1	42	95	1200 2000 3000 ^③	50	57 57 52	64 64 62	139	50	50	2.0	0.9 0.9 0.8	630 ^⑥ 1000 ^⑥ 250 ^⑥	630 ^⑥ 1000 ^⑥ —	15 18 —	3.5 2.7 —	10,000 10,000 5,000	
150VCP-W 63C	15	1	42	95	1200 2000 3000 ^③	63	62	83	175	63	50	2.0	1.1	250	400 & 1600 ^④ 400 & 1600 ^④ 400 & 1600 ^④	8.8 & 7.7 8.8 & 7.7 8.8 & 7.7	1.6 & 0.465 1.6 & 0.465 1.6 & 0.465	10,000 10,000 10,000	

① 3 cycles.

② Contact Eaton for higher RRRV or for more information.

③ 4000 A FC rating available.

④ C37.04.a-2003 Class C2 at 15 kV.

⑤ Close and Latch Current for 1200 A Type 150 VCP-W 25C is proven at 15 kV. For sealed interrupters at high altitudes, switching voltage is not derated.

⑥ Capacitor Switching Ratings are proven at 15 kV. For sealed interrupters at high altitudes, switching voltage is not derated.

Type VCP-WG Generator Circuit Breakers



VCP-WG Breaker (Front View)

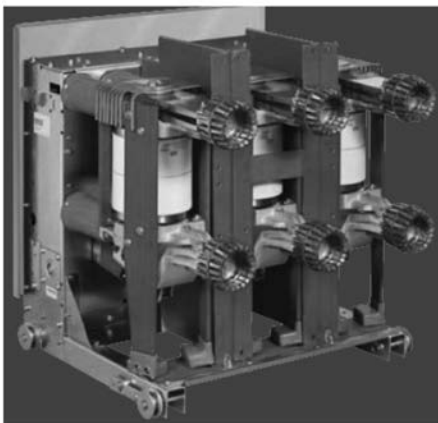

VCP-WG Breaker (Rear View)

Why generator circuit breakers?

- Specially rated generator breakers typically should be used on generator applications 10,000 kW and above
- A generator circuit breaker, properly rated and tested to the appropriate industry standard, can protect the generator from damage, or even complete failure, that could occur when feeding a faulted transformer, and also can protect the transformer, in the event that a fault should occur in the generator

Generator circuits have unique characteristics that require specially designed and tested circuit breakers. The IEEE developed the special industry standard C37.013 and amendment C37.013a-2007 to address these characteristics. Eaton has dedicated years of research, design, enhancement and testing to create Eaton's family of generator breakers.

The VCP-WG (drawout) and VCP-WRG (fixed) circuit breakers meet, and even exceed, the rigorous service duty requirements for generator circuit applications as defined by IEEE.

Eaton's VCP-WG and VCP-WRG generator breakers are available in two frame sizes. The 29.00-inch frame (29.00 inches wide with front cover on) has ratings up to 15 kV, 63 kA and 3000 A (4000 A with forced-air cooling). The 31.00-inch frame (31.00 inches wide with front cover on) has ratings up to 15 kV, 75 kA and 4000 A (5000 A with forced-air cooling). The 31.00-inch frame is also available in a fixed version with ratings up to 15 kV, 75 kA and 6000 A (7000 A with forced-air cooling).

Count on Eaton's innovative technology to handle high continuous ac current and voltage, then safely switch through extreme out-of-phase voltages and high-stress asymmetrical currents using "clean and green" vacuum interruption without fail for over 10,000 normal operations.

Eaton's VCP-WG generator circuit breakers meet the strict service duty requirements set forth by IEEE for generator circuit applications, including:

- Generator circuit configuration
- High continuous current levels
- Unique fault current conditions
 - Transformer-fed faults
 - Generator-fed faults
- Unique voltage conditions
 - Very fast RRRV
 - Out-of-phase switching

Generator Circuit Configuration

The transformer and generator can be in close proximity to the circuit breaker. See **Figure 5.1-4**. Applications with high continuous current levels require connections with large conductors of very low impedance. This construction causes unique fault current and voltage conditions as shown in **Figure 5.1-5**.

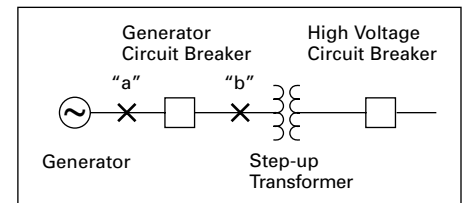

Figure 5.1-4. Generator Circuit Application

High Continuous Current Levels

Generator circuit breakers must be able to handle high continuous current levels without overheating. VCP-WG drawout circuit breakers are designed to reliably operate up to 4000 A with natural air convection cooling, and up to 5000 A with suitable enclosure fan cooling during overload conditions. VCP-WRG fixed circuit breakers are designed to reliably operate up to 6000 A with natural air convection cooling and up to 7000 A with suitable enclosure fan cooling during overload conditions.

Unique Fault Current Conditions

System-source (aka, transformer-fed) faults (see **Figure 5.1-4**, fault location “a”) can be extremely high. The full energy of the power system feeds the fault, and the low impedance of the fault current path does very little to limit the fault current. Eaton’s type VCP-WG Generator Circuit Breakers are ideal for interrupting such high fault currents because they have demonstrated high interruption ratings up to 75 kA, with high dc fault content up to 75%, as proven by high power laboratory tests.

Generator-source (aka, generator-fed) faults, see **Figure 5.1-4**, fault location “b”) can cause a severe condition called “Delayed Current Zero,” see **Figure 5.1-5**).

The high ratio of inductive reactance to resistance (X/R ratio) of the system can cause the dc component of the fault current to exceed 100%. The asymmetrical fault current peak becomes high enough and its decay becomes slow enough that the natural current zero is delayed for several cycles. The circuit breaker experiences longer arcing time and more electrical, thermal and mechanical stress during the interruption.

The IEEE standard requires verification that the circuit breaker can interrupt under these severe conditions. Eaton’s VCP-WG generator circuit breakers have demonstrated their ability to interrupt three-phase fault current levels up to 135% dc content under delayed current zero conditions.

Table 5.1-8. Generator Breaker Operations Information

Circuit Breaker Ratings			Maximum Number of Operations ①			
Rated Maximum Voltage kV rms	Rated Continuous Current Amperes	Rated Short-Circuit Current kA rms, sym.	Between Servicing	No-Load Mechanical	Rated Continuous Current Switching	Inrush Current Switching
4.76, 8.25, 15	1200, 2000	33 kA and below	2000	10,000	10,000	750
4.76, 8.25, 15	3000	All	1000	10,000	10,000	400
4.76, 15	All	37 kA and above	1000	10,000	10,000	400

① Each operation is comprised of one closing plus one opening.

Unique Voltage Conditions

Generator circuits typically produce very fast rates of rise of recovery voltage (RRRV) due to the high natural frequency and low impedance and very low stray capacitance. VCP-WG generator circuit breakers are designed to interrupt fault current levels with very fast RRRV in accordance with IEEE standard C37.013 and C37.013a. VCP-WG generator circuit breakers have a distinct ability to perform under out-of-phase conditions when the generator and power system voltages are not in sync. The voltages across the open contacts can be as high as twice the rated line-to-ground voltage of the system. The IEEE standard requires demonstration by test that the generator circuit breaker can switch under specified out-of-phase conditions.

Versatility in Application

Eaton's generator vacuum circuit breakers are available in drawout (VCP-WG) or fixed (VCP-WRG) configurations to provide for superior performance and versatility. Many industrial and commercial power systems now include small generators as a local source of power. New applications are arising as a result of the de-regulation of the utility industry, and the construction of smaller packaged power plants. Eaton's generator breakers interrupt large short-circuit currents in a small three-pole package.

Typical applications include:

- Electric utilities: fossil, hydro and wind power
- Packaged power plants
- Industrial companies using combined cycle/combustion turbine plants
- Government and military
- Commercial institutions
- Petrochemical and process industries
- Forestry, pulp and paper
- Mining, exploration and marine

The VCP-WG is the world's generator circuit breaker for reliable and robust power generation protection.

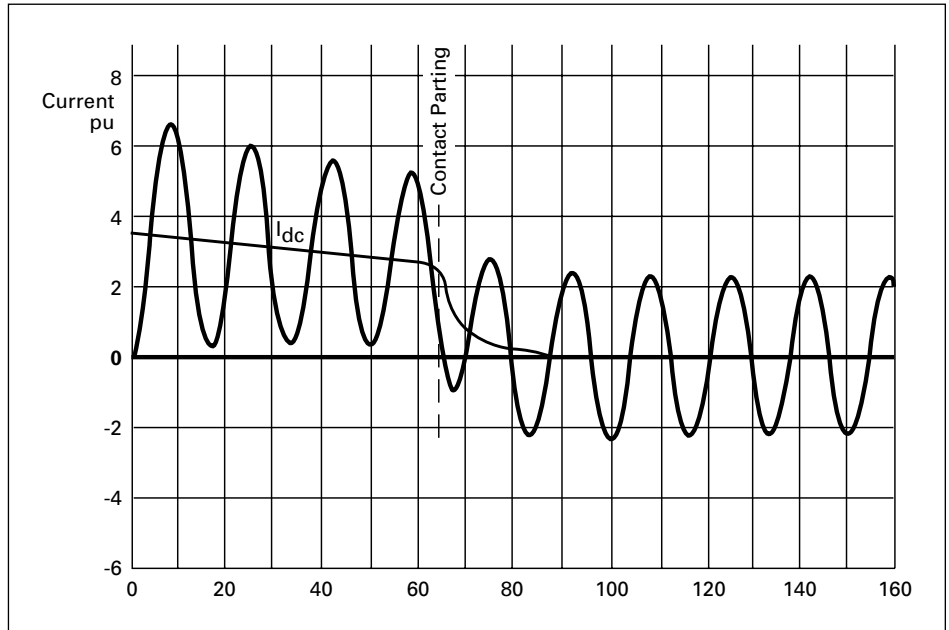

Figure 5.1-5. Generator-Fed Faults Can Experience Delayed Current Zero, Where the High Inductance to Resistance Ratio of the System Can Cause the dc Component of the Fault Current to Exceed 100%

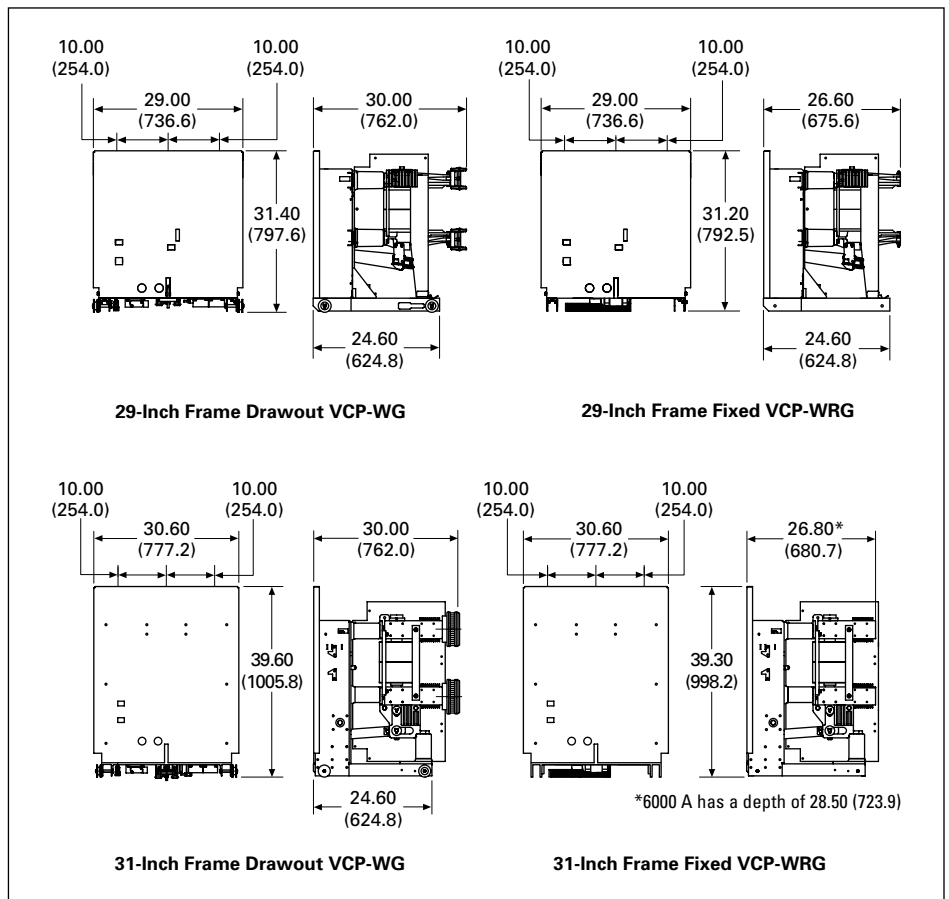

Figure 5.1-6. Type VCP-WG (Drawout) and Type VCP-WRG (Fixed) Circuit Breakers

5 kV Class Generator Circuit Breaker Ratings

Table 5.1-9. Generator Circuit Breaker Types: VCP-WG (Drawout—DO) / VCP-WRG (Fixed—FIX)

Description	Units	Short-Circuit Current (Isc)									
		50 kA		63 kA		75 kA		75 kA		75 kA	
Maximum Voltage (V): 5 kV											
Frame in Inches (mm) (see Figure 5.1-6 on Page 5.1-16)	—	29.00 (736.6)	29.00 (736.6)	31.00 (787.4)	31.00 (787.4)	29.00 (736.6)	29.00 (736.6)	31.00 (787.4)	31.00 (787.4)	31.00 (787.4)	31.00 (787.4)
Ratings Assigned	—	DO	FIX	DO	FIX	DO	FIX	DO	FIX	DO	FIX
Continuous Current	A rms	1200	1200	—	—	1200	1200	—	—	1200	1200
		2000	2000	—	—	2000	2000	—	—	2000	2000
		3000	3000	—	—	3000	3000	—	—	3000	3000
		4000 ^①	4000 ^①	4000	4000	4000 ^①	4000 ^①	4000	4000	4000	4000
		—	—	5000 ^①	5000	—	—	5000 ^①	5000	5000 ^①	5000
		—	—	—	6000	—	—	—	6000	—	6000
		—	—	—	6300 ^①	—	—	—	6300 ^①	—	6300 ^①
		—	—	—	7000 ^①	—	—	—	7000 ^①	—	7000 ^①
Dielectric Strength											
Power frequency withstand voltage	kV rms	19	19	19	19	19	19	19	19	19	19
Lightning impulse withstand voltage	kV peak	60	60	60	60	60	60	60	60	60	60
Interrupting Time	ms	50	50	83	83	50	50	83	83	83	83
Closing Time	ms	47	47	47	47	47	47	47	47	47	47
Short-Circuit Current	kA rms	50	50	50	50	63	63	63	63	75	75
Asymmetrical current interrupting capability	% dc	75	75	75	75	75	75	75	75	63	63
Ref: Minimum opening time	ms	30	30	54	54	30	30	54	54	54	54
Short-time current carrying capability	kA rms	50	50	50	50	63	63	63	63	75	75
Duration of short-time current	sec	3	3	2.3	2.3	3	3	1.4	1.4	1	1
Closing and Latching Capability	kA peak	137	137	137	137	173	173	173	173	206	206
First Generator-Source Symmetrical Current Interrupting Capability	kA rms	25	25	25	25	31.5	31.5	31.5	31.5	40	40
First Generator-Source Asymmetrical Current Interrupting Capability	% dc	130	130	130	130	130	130	130	130	130	130
Second Generator-Source Symmetrical Current Interrupting Capability	kA rms	—	—	31.5	31.5	40	40	40	40	50	50
Second Generator-Source Asymmetrical Current Interrupting Capability	% dc	—	—	110	110	110	110	110	110	110	110
Prospective TRV—Rate of Rise of Recovery Voltage (RRRV)	kV / μ s	3.0	3.0	3.0 ^②	3.0 ^②	3.0	3.0	3.0 ^②	3.0 ^②	3.0 ^②	3.0 ^②
Transient recovery voltage—Peak (E2 = 1.84 x V)	kV peak	9.2	9.2	9.2 ^②	9.2 ^②	9.2	9.2	9.2 ^②	9.2 ^②	9.2 ^②	9.2 ^②
Transient recovery voltage—Time to Peak (T2 = 0.62 x V)	μ s	3.1	3.1	3.1 ^②	3.1 ^②	3.1	3.1	3.1 ^②	3.1 ^②	3.1 ^②	3.1 ^②
Load Current Switching Endurance Capability	Operations	10,000	10,000	10,000	10,000	10,000	10,000	10,000	10,000	10,000	10,000
No-Load Mechanical Endurance Capability	Operations	10,000	10,000	10,000	10,000	10,000	10,000	10,000	10,000	10,000	10,000
Out-of-Phase Current Switching Capability	kA	25	25	25	25	31.5	31.5	31.5	31.5	37.5	37.5
90° out-of-phase power frequency recovery voltage (= 1.5 x sqrt(2/3) x V)	kV rms	6.1	6.1	6.1	6.1	6.1	6.1	6.1	6.1	6.1	6.1
90° out-of-phase inherent TRV—Rate of Rise of Recovery Voltage (RRRV)	kV / μ s	3.3	3.3	3.3	3.3	3.3	3.3	3.3	3.3	3.3	3.3
Transient recovery voltage—Peak (E2 = 2.6 x V)	kV peak	13	13	13	13	13	13	13	13	13	13
Transient recovery voltage—Time to Peak (T2 = 0.89 x V)	μ s	4.5	4.5	4.5	4.5	4.5	4.5	4.5	4.5	4.5	4.5

① Ratings achieved using forced-air cooling by blowers in the enclosure.

② TRV capacitors are required if RRRV is >0.5 kV/ μ s; or T2 is <65 μ s.

Note: Rated frequency: 60 Hz.

Note: Standard operating duty: CO - 30 m - CO.

Note: Relevant Standard: IEEE standards C37.013-1997 and C37.013a-2007.

Note: Test certificates available.

15 kV Class Generator Circuit Breaker Ratings

Table 5.1-9. Generator Circuit Breaker Types: VCP-WG (Drawout—DO) / VCP-WRG (Fixed—FIX) (Continued)

Description	Units	Short-Circuit Current (Isc)									
		50 kA		63 kA		75 kA		50 kA		75 kA	
Maximum Voltage (V): 15 kV											
Frame in Inches (mm) (see Figure 5.1-6 on Page 5.1-16)	—	29.00 (736.6)	29.00 (736.6)	31.00 (787.4)	31.00 (787.4)	29.00 (736.6)	29.00 (736.6)	31.00 (787.4)	31.00 (787.4)	31.00 (787.4)	31.00 (787.4)
Ratings Assigned	—	DO	FIX	DO	FIX	DO	FIX	DO	FIX	DO	FIX
Continuous Current	A rms	1200	1200	—	—	1200	1200	—	—	1200	1200
		2000	2000	—	—	2000	2000	—	—	2000	2000
		3000	3000	—	—	3000	3000	—	—	3000	3000
		4000 ①	4000 ①	4000	4000	4000 ①	4000 ①	4000	4000	4000	4000
		—	—	5000 ①	5000	—	—	5000 ①	5000	5000 ①	5000
		—	—	—	6000	—	—	—	6000	—	6000
		—	—	—	6300 ①	—	—	—	6300 ①	—	6300 ①
		—	—	—	7000 ①	—	—	—	7000 ①	—	7000 ①
Dielectric Strength											
Power frequency withstand voltage	kV rms	36	36	36	36	36	36	36	36	36	36
Lightning impulse withstand voltage	kV peak	95	95	95	95	95	95	95	95	95	95
Interrupting Time	ms	50	50	83	83	50	50	83	83	83	83
Closing Time	ms	47	47	47	47	47	47	47	47	47	47
Short-Circuit Current	kA rms	50	50	50	50	63	63	63	63	75	75
Asymmetrical current interrupting capability	% dc	75	75	75	75	75	75	75	75	63	63
Ref: Minimum opening time	ms	30	30	54	54	30	30	54	54	54	54
Short-time current carrying capability	kA rms	50	50	50	50	63	63	63	63	75	75
Duration of short-time current	s	3	3	2.3	2.3	3	3	1.4	1.4	1	1
Closing and Latching Capability	kA peak	137	137	137	137	173	173	173	173	206	206
First Generator-Source Symmetrical Current Interrupting Capability	kA rms	25	25	25	25	31.5	31.5	31.5	31.5	40	40
First Generator-Source Asymmetrical Current Interrupting Capability	% dc	130	130	130	130	130	130	130	130	130	130
Second Generator-Source Symmetrical Current Interrupting Capability	kA rms	—	—	31.5	31.5	40	40	40	40	50	50
Second Generator-Source Asymmetrical Current Interrupting Capability	% dc	—	—	110	110	110	110	110	110	110	110
Prospective TRV—Rate of Rise of Recovery Voltage (RRRV)	kV / μ s	3.4	3.4	3.4 ②	3.4 ②	3.4	3.4	3.4 ②	3.4 ②	3.4 ②	3.4 ②
Ref: Minimum opening time	kV peak	27.6	27.6	27.6 ②	27.6 ②	27.6	27.6	27.6 ②	27.6 ②	30.9 ②	30.9 ②
Transient recovery voltage—Peak (E2 = 1.84 x V)											
Transient recovery voltage—Time to Peak (T2 = 0.62 x V)	μ s	9.3	9.3	9.3 ②	9.3 ②	9.3	9.3	9.3 ②	9.3 ②	9.3 ②	9.3 ②
Load Current Switching Endurance Capability	Operations	10,000	10,000	10,000	10,000	10,000	10,000	10,000	10,000	10,000	10,000
No-Load Mechanical Endurance Capability	Operations	10,000	10,000	10,000	10,000	10,000	10,000	10,000	10,000	10,000	10,000
Out-of-Phase Current Switching Capability	kA	25	25	25	25	31.5	31.5	31.5	31.5	37.5	37.5
90° out-of-phase power frequency recovery voltage (= 1.5 x sqrt(2/3) x V)	kV rms	18.4	18.4	18.4	18.4	18.4	18.4	18.4	18.4	18.4	18.4
90° out-of-phase inherent TRV—Rate of Rise of Recovery Voltage (RRRV)	kV / μ s	3.3	3.3	3.3	3.3	3.3	3.3	3.3	3.3	3.3	3.3
Transient recovery voltage—Peak (E2 = 2.6 x V)	kV peak	39	39	39	39	39	39	39	39	39	39
Transient recovery voltage—Time to Peak (T2 = 0.89 x V)	μ s	13.4	13.4	13.4	13.4	13.4	13.4	13.4	13.4	13.4	13.4

① Ratings achieved using forced-air cooling by blowers in the enclosure.

② TRV capacitors are required if RRRV is >0.5 kV/ μ s; or T2 is <65 μ s.

Note: Rated frequency: 60 Hz.

Note: Standard operating duty: CO - 30 m - CO.

Note: Relevant Standard: IEEE standards C37.013-1997 and C37.013a-2007.

Note: Test certificates available.

Switchgear Meters



Switchgear Meters

Eaton's Power Xpert® Power and Energy Meters, and Power Xpert Dashboard products allow switchgear owners and operators to interface with their equipment at varying levels of sophistication. To learn more about these devices, visit our web or click on links above.

Protective Relays



Protective Relays

Eaton can provide a wide range of protective relays to meet you most complex protection and system needs.

Instrument Transformers

Instrument transformers are used to protect personnel and secondary devices from high voltage, and permit use of reasonable insulation levels for relays, meters and instruments. The secondaries of standard instrument transformers are rated at 5 A and/or 120V, 60 Hz.

Voltage Transformers

Selection of the ratio for voltage transformers is seldom a question because the primary rating should be equal to or higher than the system line-to-line voltage. The number of potential transformers per set and their connection is determined by the type of system and the relaying and metering required.

When two VTs are used, they are typically connected L-L, and provide phase-to-phase voltages, (Vab, Vbc, Vca) for metering and relaying.

When three VTs are used, they are connected line-to-ground, and provide phase-to-phase (Vab, Vbc, Vca), as well as phase-to-ground (Va, Vb, Vc) voltages for metering and relaying.

If metering or relaying application requires phase-to-ground voltages, use three VTs, each connected L-G. If not, use of two VTs connected L-L is sufficient.

For ground detection, three VTs connected in Line-to-ground/ broken-delta are used.

A single VT, when used, can be connected line-to-line (it will provide line-to-line output, for example Vab or Vbc or Vca), or line-to-ground (it will provide line-to-ground output, for example Va or Vb or Vc). Generally, a single VT is used to derive voltage signal for synchronizing or Over Voltage/Under Voltage function. Refer to **Table 5.1-10** and **Table 5.1-11** for standard VT ratio and accuracy data.

Current Transformers

The current transformer ratio is generally selected so that the maximum load current will read about 70% full scale on a standard 5 A coil ammeter. Therefore, the current transformer primary rating should be 140–150% of the maximum load current.

Maximum system fault current can sometimes influence the current transformer ratio selection because the connected secondary devices have published one-second ratings.

The zero-sequence current transformer is used for sensitive ground fault relaying or self-balancing primary current type machine differential protection. The zero-sequence current transformer is available with a nominal ratio of 50/5 or 100/5 and available opening size for power cables of 7.25 inches (184.2 mm). Special zero-sequence transformers with larger windows are also available.

The minimum number of current transformers for circuit relaying and instruments is three current transformers, one for each phase or two-phase connected current transformers and one zero-sequence current transformer. Separate sets of current transformers are required for differential relays.

The minimum pickup of a ground relay in the residual of three-phase connected current transformers is primarily determined by the current transformer ratio. The relay pickup can be reduced by adding one residual connected auxiliary current transformer. This connection is very desirable on main incoming and tie circuits of low resistance grounded circuits.

Standard accuracy current transformers are normally more than adequate for most standard applications of microprocessor-based protective relays and meters. See **Table 5.1-12** for CT accuracy information.

Table 5.1-10. Standard Voltage Transformer Ratio Information

Rating-Volts	2400	4200	4800	7200	8400	10800	12000	14400
Ratio	20-1	35-1	40-1	60-1	70-1	90-1	100-1	120-1

Table 5.1-11. Standard Voltage Transformer, 60 Hz Accuracy Information

Switchgear		Voltage Transformer – ANSI Accuracy											
kV Class	kV BIL	Maximum Number Per Set and Connection	Standard Ratios	Burdens at 120 Volts				Burdens at 69.3 Volts				Thermal Rating 55 °C Connection	Volt-Ampere
				W, X, Y	Z	M	ZZ	W, X	Y	M	Z		
5	60	2LL or 3LG	20, ① 35, 40	0.3	1.2	–	–	0.3	–	–	–	LL LG LG ②	700 400 700
7.5 and 15	95	2LL or 3LG	35, 40, 60, 70, 100, 120	0.3	0.3	0.3	0.6	0.3	0.3	0.3	1.2	LL LG LG ②	1000 550 1000

① For solidly grounded 4160V system only or any type 2400V system.

② For solidly grounded system only.

Note: LL = Line-to-line connection. LG = Line-to-ground connection.

Table 5.1-12. Current Transformers, 55 °C Ambient

CT Ratio (MR = Multi-Ratio)	Metering Accuracy Classification Percentage			Relaying Accuracy Classification		
	At 60 Hz Standard Burden B 0.1 Ohms	At 60 Hz Standard Burden B 0.5 Ohms	At 60 Hz Standard Burden B 1.8 Ohms	Minimum Accuracy Required per IEEE C37.20.2	Standard Accuracy Supplied in VCP-W Switchgear	Optional High Accuracy Available in VCP-W Switchgear
50:5	1.2	–	–	C10	–	C10
75:5	1.2	2.4	–	C10	C10	C20
100:5	1.2	2.4	–	C10	C10	C20
150:5	0.6	2.4	–	C20	C20	C50
200:5	0.6	2.4	–	C20	C20	C50
250:5	0.6	2.4	–	③	C20	C50
300:5	0.6	2.4	2.4	C20	C20	C100
400:5	0.3	1.2	2.4	C50	C50	C100
500:5	0.3	0.3	2.4	③	C50	C100
600:5	0.3	0.3	2.4	C50	C100	C200
800:5	0.3	0.3	1.2	C50	C100	C200
1000:5	0.3	0.3	0.3	③	C100	C200
1200:5	0.3	0.3	0.3	C100	C200	C400
1500:5	0.3	0.3	0.3	C100	C200	C400
2000:5	0.3	0.3	0.3	C100	C200	C400
2500:5	0.3	0.3	0.3	③	C200	C400
3000:5	0.3	0.3	0.3	C100	C200	C400
4000:5	0.3	0.3	0.3	C100	C200	C400
600:5 MR	0.3	0.3	2.4	③	C100	C200
1200:5 MR	0.3	0.3	0.3	③	C200	C400
2000:5 MR	0.3	0.3	0.3	③	C200	C400
3000:5 MR	0.3	0.3	0.3	③	C200	C400
50:5 zero sequence	–	–	–	–	C10	–
100:5 zero sequence	–	–	–	–	C20	–

③ Not listed in C37.20.2.

Note: Maximum number of CTs— Two sets of standard accuracy or one set of high accuracy CTs can be installed in the breaker compartment on each side of the circuit breaker.

Ohmic Voltage Sensing (OVS)

Eaton's Ohmic Voltage Sensing (OVS) is an alternative to traditional VTs in medium voltage. While traditional VTs are susceptible to transients and ferro-resonance, the OVS system is not. The OVS system consists of three resistive voltage divider sensors connected to an amplifier. The sensors reduce the voltage from the primary voltage to a lower voltage which is then transmitted to the amplifier to provide an output of 120 Vac to meters and relays (see **Figure 5.1-7**). The system can be utilized with various meter and relay selections used in protection and control schemes.

The OVS system is rated for applications 2.4 to 36 kV as a replacement for VTs. The selection of sensors for the system is dependent on the nominal voltage being applied to the switchgear. The OVS systems must be applied with three sensors installed line to ground; the low-voltage control circuit can be configured to provide a line-to-line or a line-to-ground output dependent upon the wiring to the relay or meter. Relays and meters installed in the protection and controls scheme would process the signal from the OVS system in the same manner it would a VT. The sensors are traditionally mounted in the rear switchgear compartment (see **Figure 5.1-8**). However, if an existing installation requires the OVS system, it can be retrofitted into the existing VT drawer.

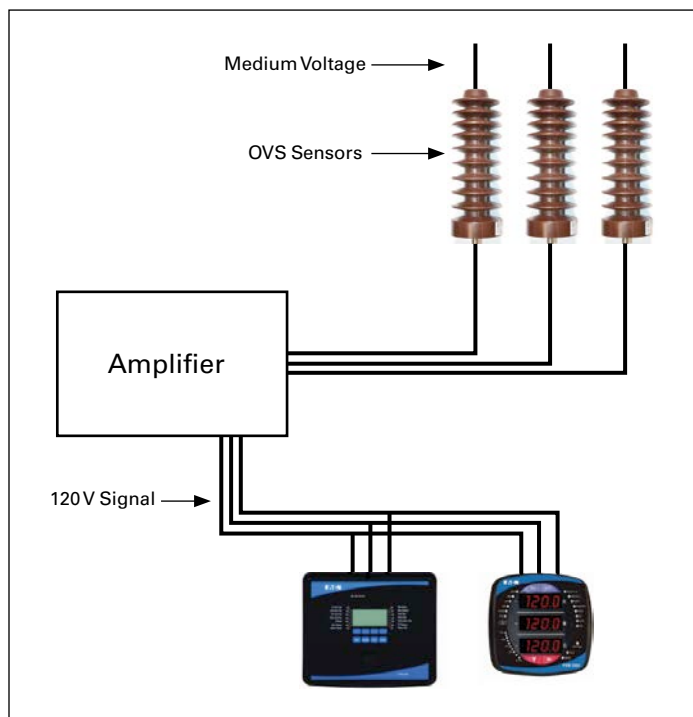

Figure 5.1-7. Typical OVS System Setup



Figure 5.1-8. OVS Sensors Mounted in Cable Compartment

OVS is not to be used to provide control power to devices in the switchgear, or to be used for utility metering applications.

The OVS system has been tested to IEEE C37.20.2.2015 Annex D.

Technical Data

- 24 to 230 Vac or Vdc control power for amplifier
- Voltage system accuracy better than 1%
- Phase angle accuracy of better than 0.1% over frequency range of 2 kHz
- Burden 0.78 VA L-L, 0.45 VA L-N

Thermal Monitoring

Eaton can provide multiple options for thermal monitoring in switchgear. From infrared (IR) windows to continuous thermal monitoring solutions.

IR windows are placed on the rear covers of the switchgear doors providing the ability to use an IR camera for checking cable connections to circuit breakers. IR windows are applied in different configurations depending on the field of view each window has into the cable compartment of the switchgear. An IR camera is needed for taking pictures through the window to check system health. See **Figure 5.1-9** for IR window installation example.

Continuous thermal monitoring systems consist of sensors mounted in the cable compartment, which are hardwired or wireless and connected to a data card or collector to put the information over a control network to be monitored. The temperature measured is a delta t (ambient to bus temperature); some systems require a second sensor for ambient temperature. See **Figure 5.1-10** for a continuous thermal monitoring system installation example.

The delta t that can be taken from both systems should be analyzed and compared to industry standards to determine any corrective action required.

Dummy Element (Dummy Breaker)

Dummy element is a drawout element with primary disconnects similar to a drawout circuit breaker, but consists of solid copper conductors in place of vacuum interrupters, and is designed for manual racking. It is typically used as drawout disconnect link in the primary system for circuit isolation or bypass.

The device is insulated to suit the voltage rating of the switchgear and will carry required levels of short-circuit current, but it is not rated for any current interruption. It must be key interlocked with all source devices such that it can only be inserted into or removed from its connected position only after the primary circuit in which it is to be applied is completely de-energized.

Before using a dummy element, it is recommended that each user develop detailed operating procedure consistent with safe operating practices. Only qualified personnel should be authorized to use the dummy element.



Figure 5.1-9. Typical Install for IR Window on Rear Door



Figure 5.1-10. Typical Install for Continuous Thermal Monitoring Sensors

Roll-on-the-Floor Breaker Option



Roll-on-the-Floor Switchgear Compartment

An optional direct roll-in breaker designed for use in upper and lower compartment of 5/15 kV indoor and outdoor walk-in aisle switchgear is available for all 5/15 kV VCP-W, VCP-WC and VCP-WG circuit breakers. Breaker is fitted with special wheel kit, and compartment interface is modified to allow circuit breaker to be rolled directly from the floor into the switchgear compartment, or from switchgear compartment onto the floor without a need for external lifting device or dolly. Circuit breakers with roll-on-the-floor wheels are supplied with four fixed wheels. In 2-high construction, the roll-on-the-floor breaker option is available for breakers in upper or lower compartments, however, removal of upper breaker requires external lifter and lift pan, which are optional accessories.

When using a 1200 or 2000 A circuit breaker in the lower compartment, the compartment above the breaker can be left blank or used of auxiliaries, such as VTs or single-phase CPT, or primary fuses for three-phase or larger than 15 kVA single-phase CPTs. When using 3000 A circuit breaker in the lower compartment, the compartment above the breaker is left blank for ventilation. The design is rated for application in IBC/CBC seismic environment. It can also be supplied with UL or CSA label for certain ratings. Contact Eaton for ratings available with UL/CSA label. The overall dimensions of the 5/15 kV indoor and outdoor walk-in aisle structures with the roll-on-the-floor breaker option are the same as the standard structures that use standard non roll-on-the-floor circuit breakers.

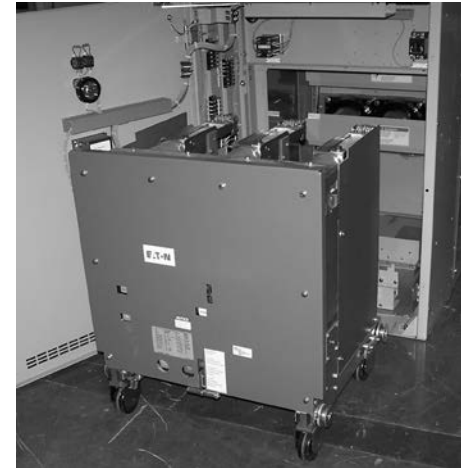

VCP-W Direct Roll-in Breaker with Fixed Wheels

Integral Motorized Remote Racking Option (VCP-W MR2)

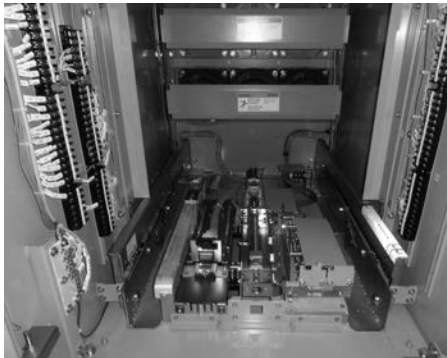

Breaker Levering Pan Assembly with Test Position – VCP-W MR2 Integral Racking Device

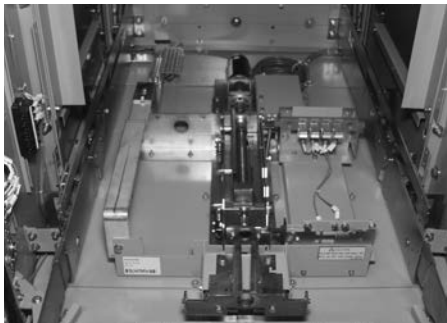

Type VCP-W Arc-Resistant Switchgear Auxiliary Drawer with Type MR2 Integral Racking



Type VCP-W Standard Switchgear Auxiliary Drawer with Type MR2 Integral Racking



MR2 Hand-Held Pendant

VCP-W MR2 is an optional motorized racking device accessory installed inside a circuit breaker or auxiliary compartment. It is available for application in circuit breaker compartments of 5/15/27/38 kV Type VCP-W arc and non-arc, and 5 kV VCP-W ND metal-clad switchgear. It is also available for application in auxiliary compartments of 5/15 kV Type VCP-W arc-resistant and standard switchgear. This optional accessory allows a user to safely move a circuit breaker between Connected, Test and Disconnected positions and auxiliary drawer (VT, CPT, primary fuse) between Connected and Disconnected positions within their respective compartments from a safe distance away from the switchgear. The MR2 controller also allows a user to electrically open and close the circuit breaker from a safe distance away from the switchgear. For switchgear designs/ratings not included above, contact Eaton for availability of MR2 accessory.

A microprocessor-based controller card, located below the drive motor, interfaces with an external hand-held pendant (standard), discrete external I/O (optional) or external Modbus® communication (optional) and controls the breaker/auxiliary drawer movement via the drive motor. The system is also designed such that it allows manual racking of the breaker/auxiliary using the levering crank accessory if needed. The VCP-W MR2 controller interface is shown in **Figure 5.1-11**. The crank safety switch disables the motor whenever a breaker/auxiliary is being manually racked in or out. The connect, test and disconnect limit switches provide breaker/auxiliary position inputs to the controller card. In addition to the standard permissive switch, two terminals are provided for connection of the customer's external interlocking/permissive contact(s). Note that a single-phase 120 Vac control supply is required for proper operation of the VCP-W MR2 controller and the drive motor.

When VCP-W MR2 integral racking is supplied, its controller card is wired to the CAT 6 jack installed in the associated breaker/auxiliary compartment door, and each switchgear lineup is shipped with one hand-held pendant with 30 feet of CAT 6 cable (lengths up to 100 ft available). The pendant interfaces with the MR2 controller card via the CAT 6 cable through a CAT 6 jack located on the breaker/auxiliary compartment door. It allows the operator to move away from the switchgear up to 30 feet. The pendant includes Enable pushbutton for additional security. It must be pressed in order to activate the pendant functions. By pressing Enable pushbutton and an appropriate function pushbutton together momentarily, the operator can rack the breaker between Connected, Test and Disconnected positions or open or close the breaker or rack the auxiliary drawer between Connected and Disconnected positions. Breaker or auxiliary drawer positions (Connect, Test, Disconnect) and breaker opened/closed status are indicated by appropriate LED lights on the pendant. A blinking light indicates that the breaker/auxiliary is in motion through the selected position.

A solid (non-blinking) light indicates that the breaker/auxiliary has reached and stopped in the selected position. In case normal operation fails, the appropriate error code is displayed in a separate two-character LED display window on the pendant. A list of various error codes and their descriptions along with suggested corrective actions are printed on the back side of the pendant. Examples of error states: motor overcurrent, motor overtemperature, motor timed out, breaker position unknown, open permissive, communication error and no breaker/auxiliary.

In addition to pendant, three optional I/O interfaces can be supplied as follows:

1. I/O interface to allow racking of breaker (connect, test, disconnect) or auxiliary drawer (connect, disconnect) by external hardwired dry contacts and 24 Vdc output for corresponding remote position indicating LEDs.
2. I/O board that provided dry contacts for remote indication of breaker (connect, intermediate, test, disconnect)/auxiliary drawer (connect, test) position within its compartment.
3. I/O interface to allow breaker open/close functions via external hardwired dry contacts and 24 Vdc output for corresponding remote open/close status LEDs.

The remote LED lights are not included with MR2. If the customer needs to operate the MR2 with the hand-held pendant, the pendant becomes the master and will override the customer's remote control signals.

The VCP-W MR2 controller is also equipped with terminal blocks to allow the customer to interface with the controller via their SCADA system using a Modbus interface. Please note that only one of the two options, discrete I/O interface or Modbus interface, can be used, but not both.

Figure 5.1-12 shows an illustration of a typical Modbus control example. Additional components shown outside the MR2 controller in **Figure 5.1-12** are not included with the MR2. System-level controls can be optionally supplied by Eaton's Engineering Services & Systems. If the customer needs to operate the MR2 with the hand-held pendant, the pendant becomes the master and will override the Modbus interface. Error codes are displayed on Modbus devices when controlling the MR2 with Modbus and on the pendant when controlling with the pendant.

Technical Data

Control Supply Ratings

- Nominal control voltage—120 Vac, 50 or 60 Hz, single-phase
- Control voltage range—100 to 140 Vac, 50 or 60 Hz
- Time to travel from connect to disconnect, or disconnect to connect—50 seconds maximum
- Current draw during the travel—15 A maximum for about 3 seconds and 3.6 A for about 24 seconds
- Optional dry output contacts when included for position indications are rated for 125 Vac, 2 A
- External permissive contacts, when used, must be rated for 24 Vdc, 50 mA

Requirements for External Contacts and LEDs when Interfacing with MR2

- External contacts should be rated for minimum open circuit voltage of 24 Vdc, and be able to close and carry 5 mA at 24 Vdc
- When remote LEDs are used, use 24 Vdc rated LEDs, current up to 20 mA
- Optional dry output contacts when included for position indications are rated for 125 Vac, 2 A
- External permissive contacts, when used, must be rated for 24 Vdc, 50 mA

It is the customer's responsibility to provide single-phase 120 V, 50 or 60 Hz nominal supply for the MR2 controller. It can be derived from within the switchgear if an appropriate control power transformer is available within the switchgear.

Type VCP-W MR2 motorized racking accessory has been endurance tested and guaranteed for 500 operations as required by IEEE C37.20.2.

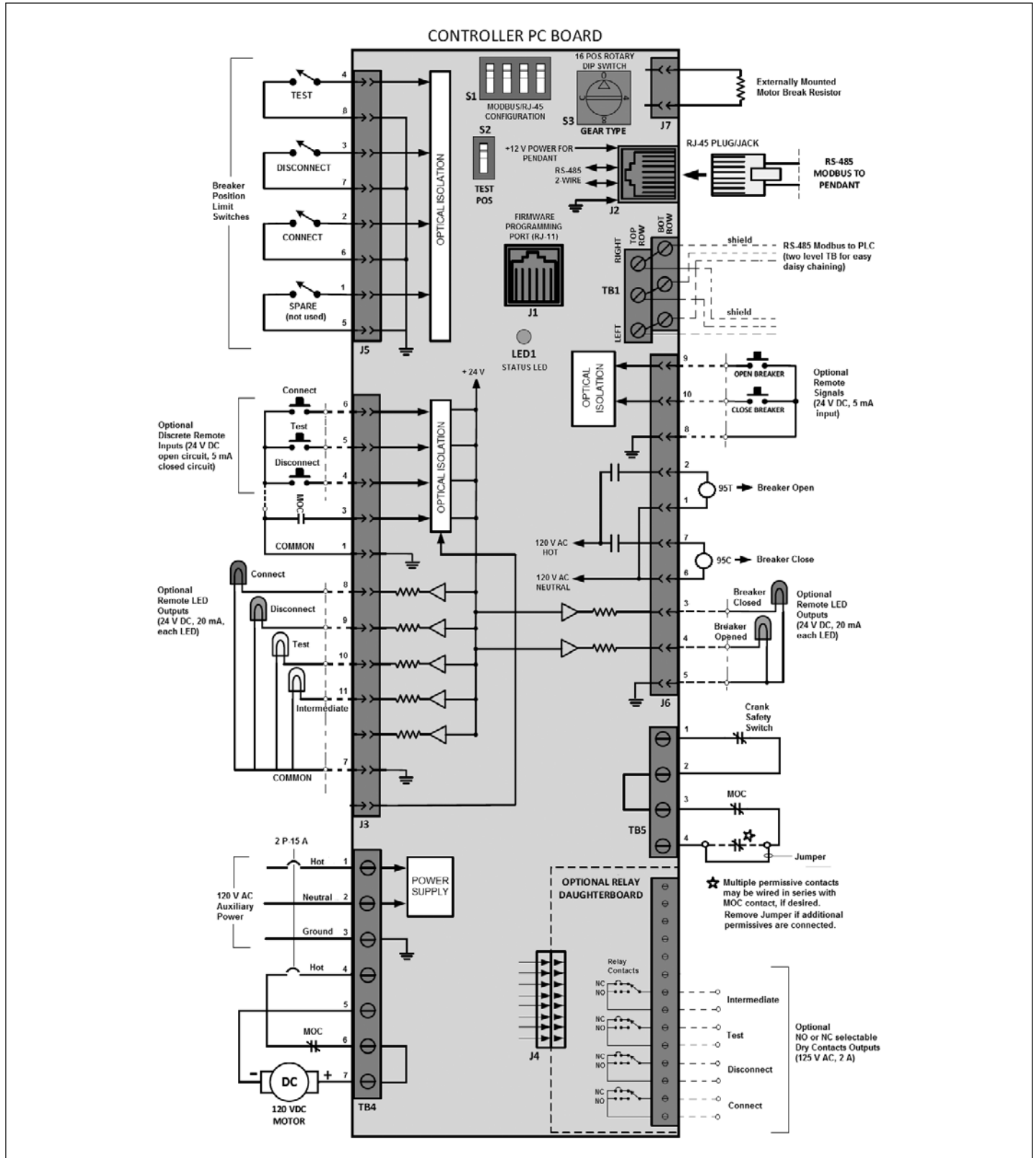

Figure 5.1-11. VCP-W MR2 Controller Interface for a VCB with Distinct Test Position and Open/Close Functions

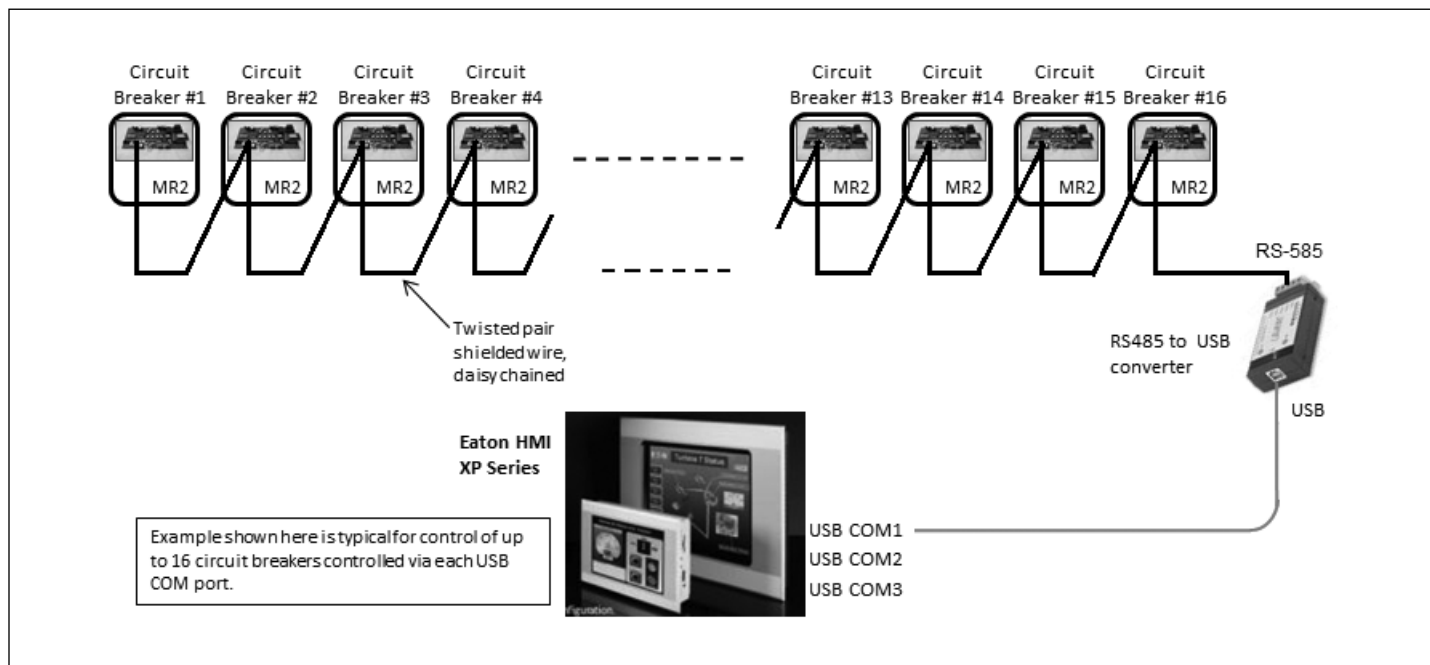

Figure 5.1-12. VCP-W MR2 Typical Modbus Control Example

Accessories

Eaton 5–15 kV switchgear is provided with the following accessories as standard:

- One test jumper
- One levering crank
- One maintenance tool
- One lifting yoke (5–27 kV)
- One sets of rails (5–27 kV)

The following optional accessories are also available. Contact Eaton for additional information.

Optional Accessories

- Transport dolly (5–27 kV), (5–15 kV arc-resistant)
- Portable lifter (5–27 kV)
- Test cabinet
- Electrical levering device (5–38 kV)
- Ramp for lower breaker (5–27 kV), (5–15 kV arc-resistant)
- Manual or electrical ground and test device
- Hi-pot tester

Ground and Test Device

The ground and test device is a drawout element that may be inserted into a metal-clad switchgear housing in place of a circuit breaker to provide access to the primary circuits to permit the temporary connection of grounds or testing equipment to the high-voltage circuits. High potential testing of cable or phase checking of circuits are typical tests which may be performed. The devices are insulated to suit the voltage rating of the switchgear and will carry required level of short-circuit current.

Before using ground and test devices, it is recommended that each user develop detailed operating procedures consistent with safe operating practices. Only qualified personnel should be authorized to use ground and test devices.

Manual and electrical ground and test devices are available. These devices include six studs for connection to primary circuits. On the manual device, selection and grounding is accomplished by cable or bus bars connection. On electrical-type devices, grounding is accomplished by an electrically operated grounding switch.



5/15 kV Manual Type G&T Device



5/15 kV Manual G&T Device shown with Upper Terminals Grounded



5/15 kV Manual G&T Device shown with Lower Terminals Grounded

InsulGard Partial Discharge Sensing and Monitoring

Partial Discharge Sensing and Monitoring for Switchgear



InsulGard Relay



RFCT Sensor

Partial Discharge Equipment



InsulGard Relay (PD Monitoring)

Partial Discharge in Switchgear

Partial discharge is a common name for various forms of electrical discharges such as corona, surface tracking, and discharges internal to the insulation. It partially bridges the insulation between the conductors. These discharges are essentially small arcs occurring in or on the surface of the insulation system when voltage stress exceeds a critical value. With time, airborne particles, contaminants and humidity lead to conditions that result in partial discharges. Partial discharges start at a low level and increase as more insulation becomes deteriorated. Examples of partial discharge in switchgear are surface tracking across bus insulation, or discharges in the air gap between the bus and a support, such as where a bus passes through an insulating window between the sections of the switchgear. If partial discharge process is not detected and corrected, it can develop into a full-scale insulation failure followed by an electrical fault. Most switchgear flashover and bus failures are a result of insulation degradation caused by various forms of partial discharges.

Sensing and Monitoring

Eaton's Type VCP-W metal-clad switchgear (2.4–38 kV) is corona-free by design. Corona emissions within the standard VacClad switchgear assemblies have been eliminated or reduced to very low levels by special fabrication and assembly techniques, such as rounding and buffing of all sharp copper edges at the joints, employing star washers for bolting metal barriers, and using specially crafted standoff insulators for primary bus supports. By making switchgear assemblies corona-free, Eaton has made its standard switchgear more reliable. However, as indicated above, with time, airborne particles, contaminants and humidity lead to conditions that cause partial discharges to develop in switchgear operating at voltages 4000 V and above. Type VCP-W switchgear can be equipped with factory-installed partial discharge sensors and partial discharge sensing relay for continuous monitoring of the partial discharges under normal operation. Timely detection of insulation degradation through increasing partial discharges can identify potential problems so that corrective actions can be planned and implemented long before permanent deterioration develops. Partial discharge detection can be the foundation of an effective predictive maintenance program. Trending of partial discharge data over time allows prediction of failures, which can be corrected before catastrophic failure occurs.

The PD sensing and monitoring system is optional. It consists of Eaton's InsulGard™ Relay and PD sensors specifically developed for application in the switchgear to work with the relay.

Partial discharges within the switchgear compartment are detected by installation of a small donut type radio frequency current transformer (RFCT) sensor over floating stress shields of the specially designed bus or line side primary bushings. Partial discharges in customer's power cables (external discharges) are detected by installation of the RFCT around ground shields of the incoming or outgoing power cables termination.

In 5/15 kV switchgear (refer to **Figure 5.1-14**), primary epoxy bushings with stress shield and RFCT sensors for measurement of internal as well as external partial discharges are all optional. InsulGard relay is also optional. When specified, one set of primary epoxy bushings (located on bus side) with stress shield and associated RFCT sensor is provided at every two vertical sections. An additional RFCT sensor for each incoming and outgoing power cable circuits can be provided as required. The RFCT output signals can be connected directly to InsulGard relay for continuous monitoring of partial discharges or can be used for periodic field measurements.

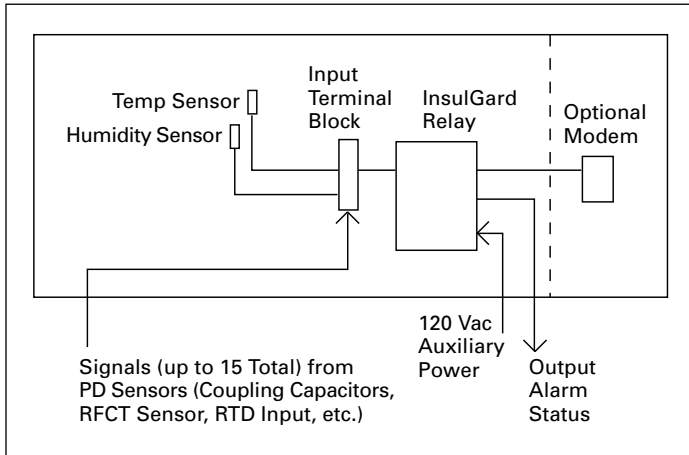

Figure 5.1-13. InsulGard Relay System

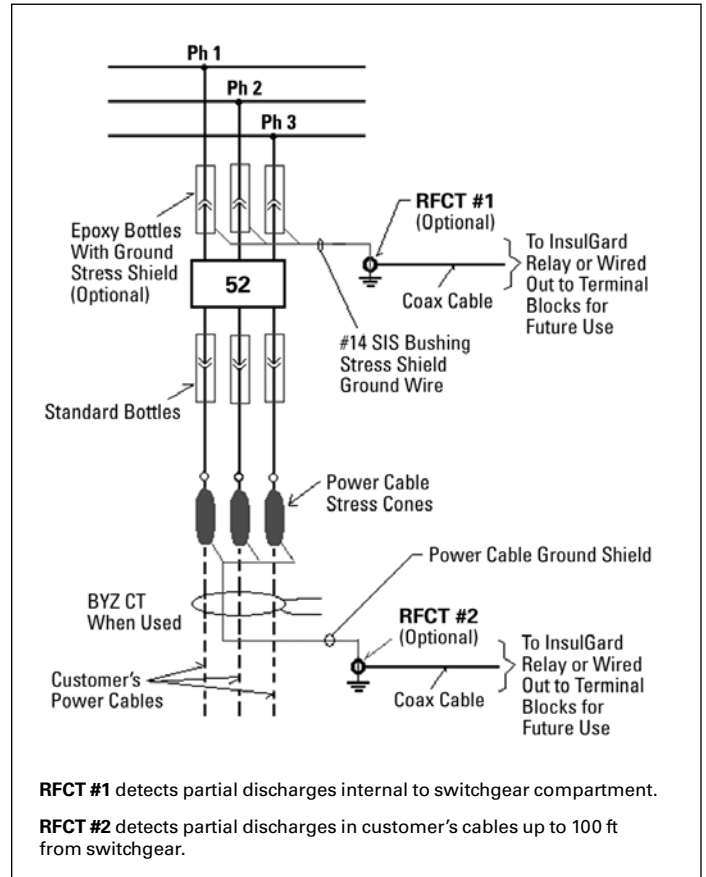

Figure 5.1-14. Typical Partial Discharge Sensor Connections (5–15 kV Switchgear)

Note: Use one set of epoxy bottles with ground stress shield on bus side (either in the top or bottom compartment) at every two vertical sections. Use standard bottles at all other locations.

Partial Discharge Sensors and Monitoring for Switchgear

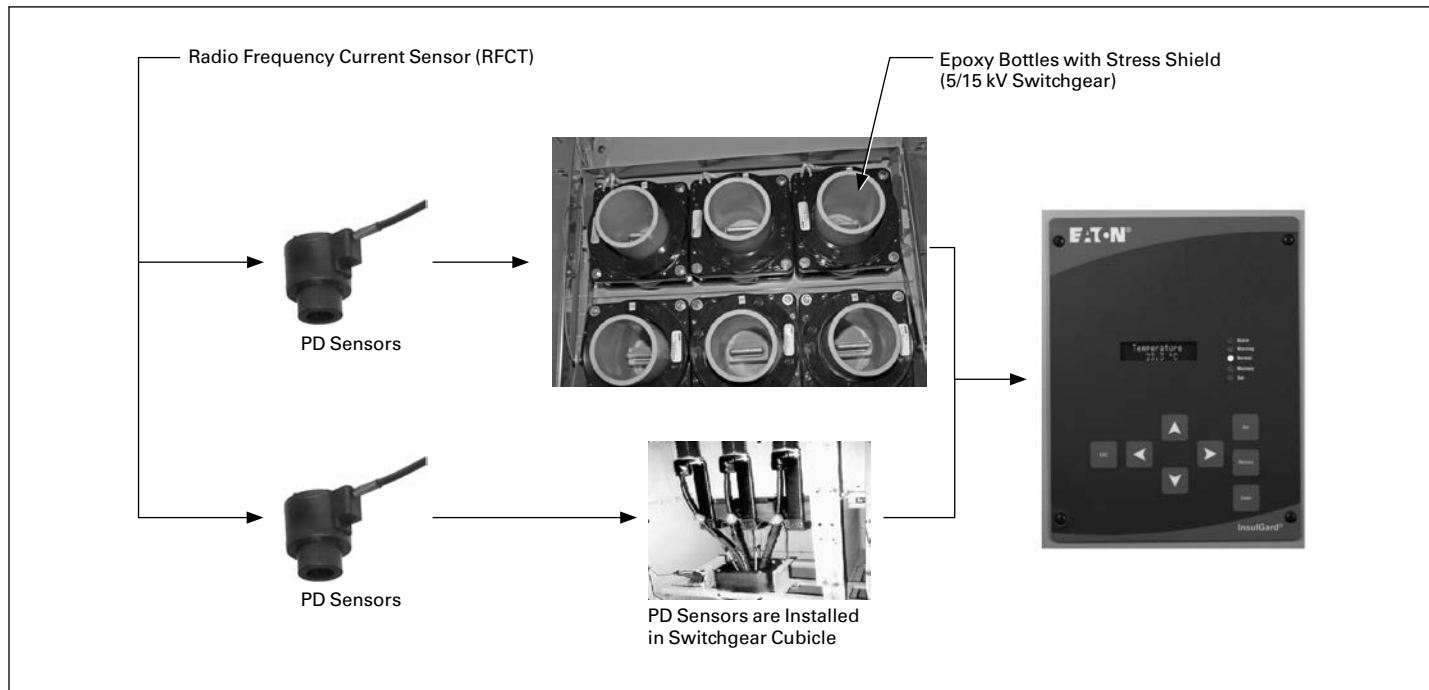

Figure 5.1-15. How the Process Works—Sensing and Data Collection

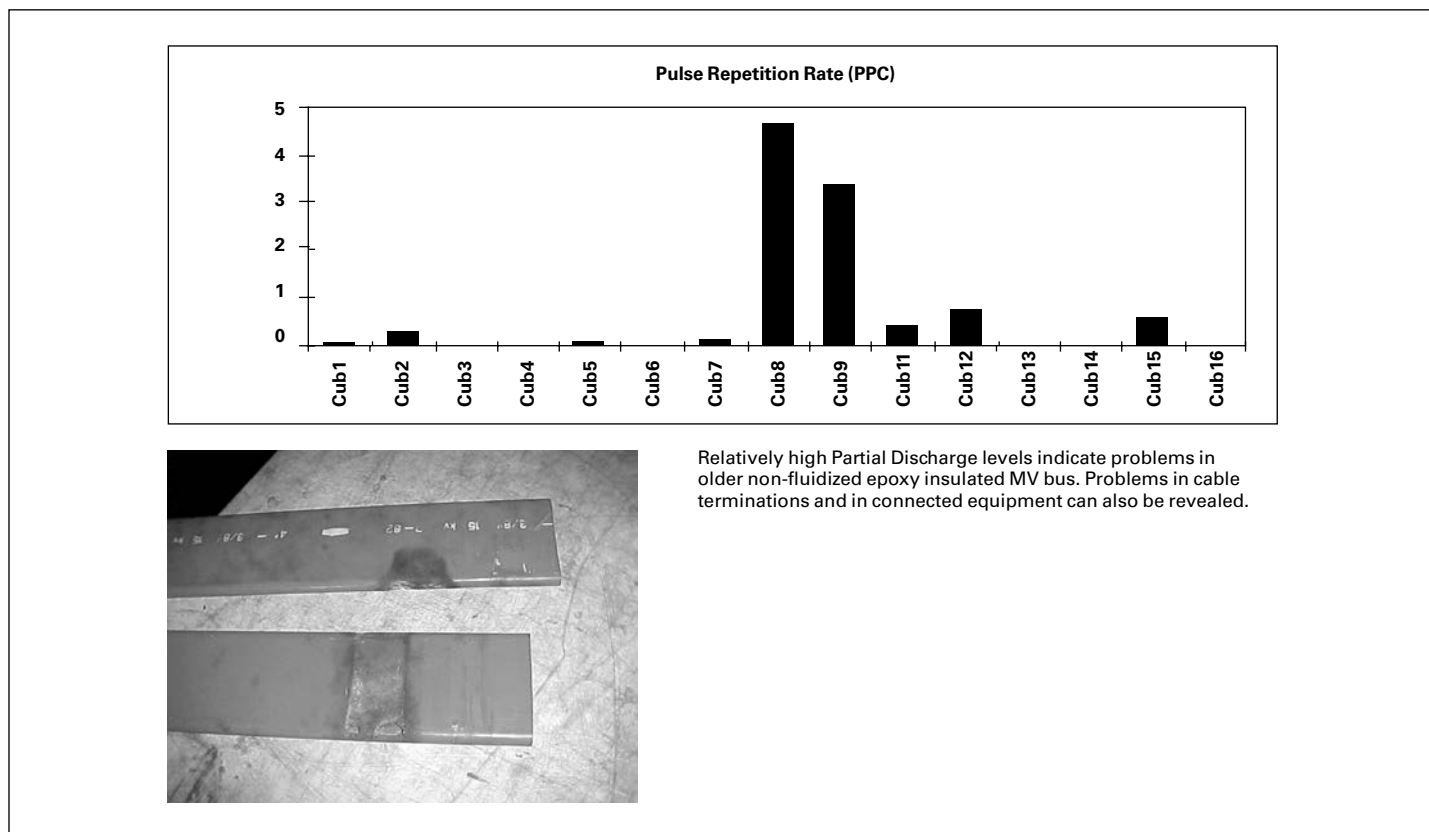

Figure 5.1-16. How the Process Works—Data Analysis and Report (Sample)

Standard Height—Layouts

Typical Main-Tie-Main Arrangements (Standard Metal-Clad)

Note: Arrangements shown in Figures 5.1-13–5.1-15 can be provided in 26.00-inch (660.4 mm) wide, 95.00-inch (2413.0 mm) high, 96.25-inch (2444.8 mm) deep structures with 50VCPWND, 1200 A circuit breakers.

Note: R = Multi-function relay, M = Multi-function meter.

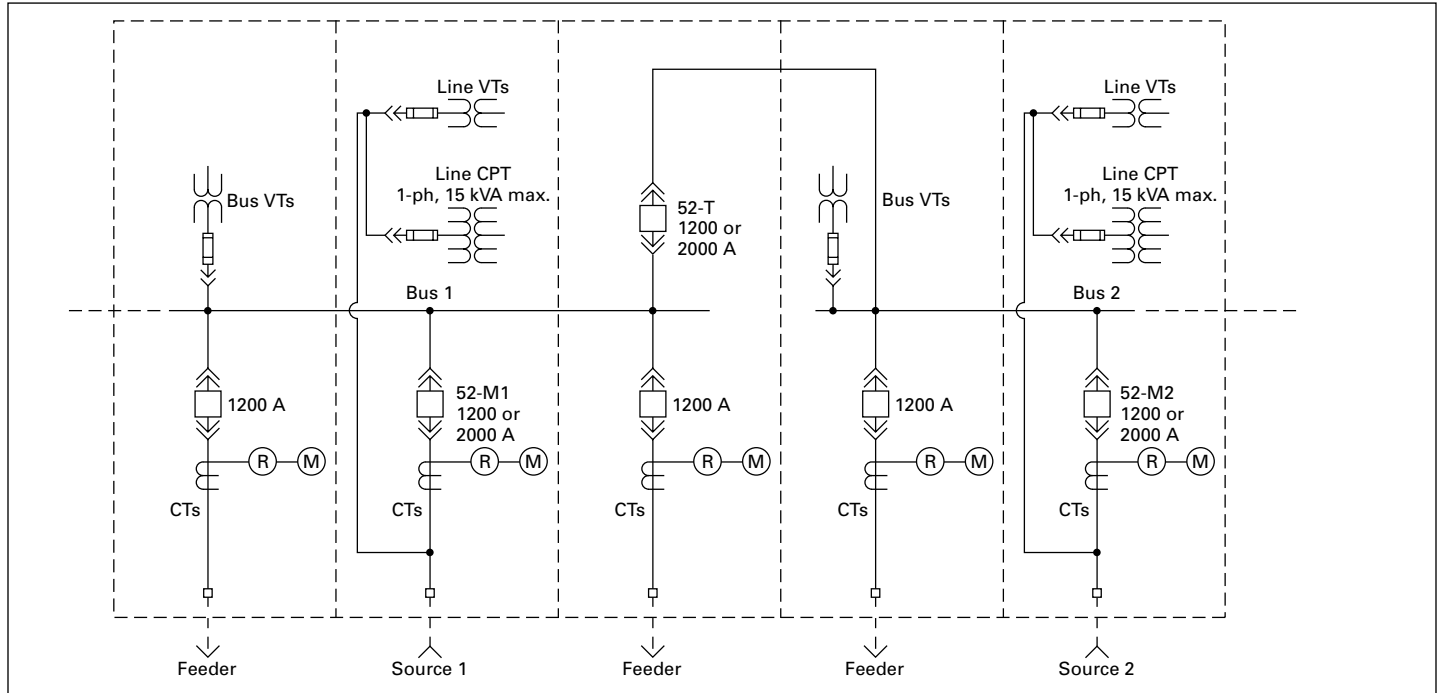

Figure 5.1-17. Typical Main-Tie-Main Arrangement with Bus and Line VTs and Line CPTs
 5 or 15 kV VCP-W Switchgear, 1200 or 2000 A Mains and Tie, 36.00-Inch (914.4 mm) Wide Structures

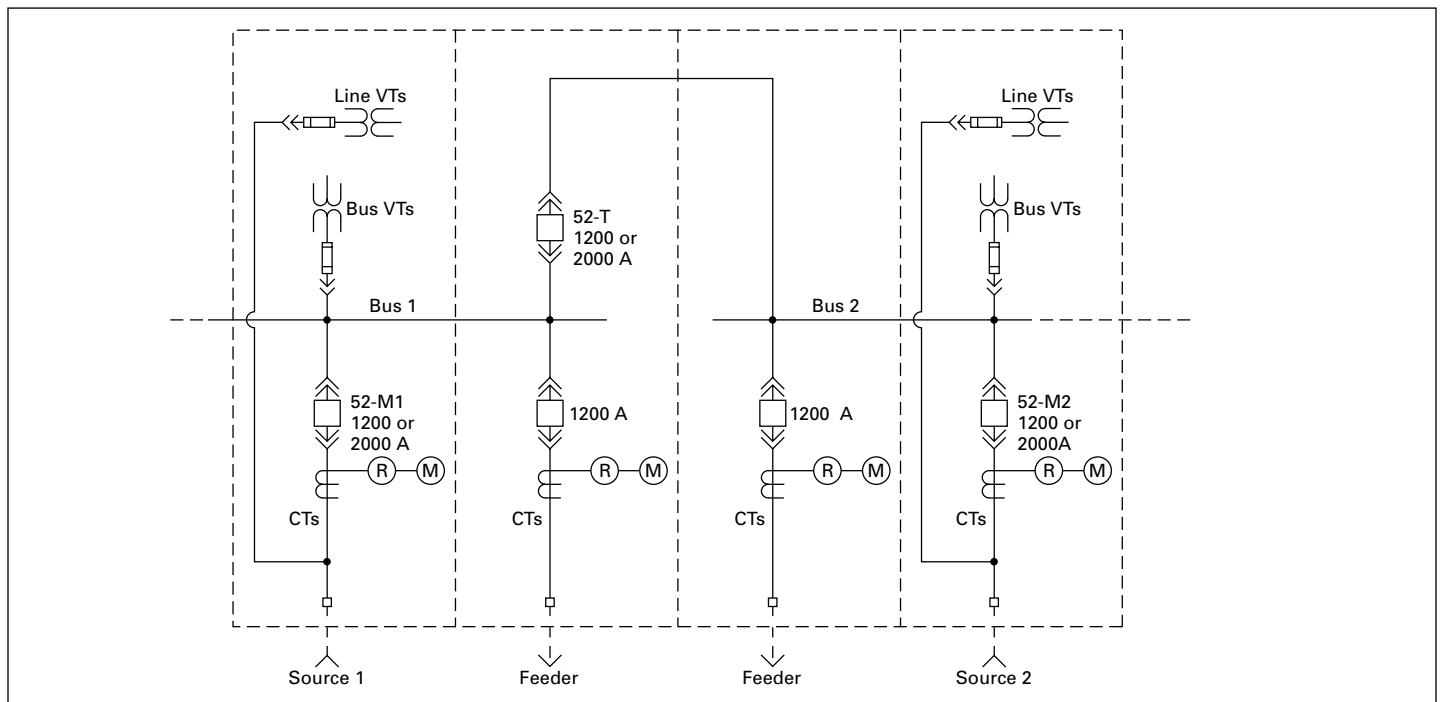

Figure 5.1-18. Typical Main-Tie-Main Arrangement with Bus and Line VTs, but without Line CPTs—Preferred Arrangement
 5 or 15 kV VCP-W Switchgear, 1200 or 2000 A Mains and Tie, 36.00-Inch (914.4 mm) Wide Structures

Typical Main-Tie-Main Arrangements (Continued)

Note: R = Multi-function relay, M = Multi-function meter

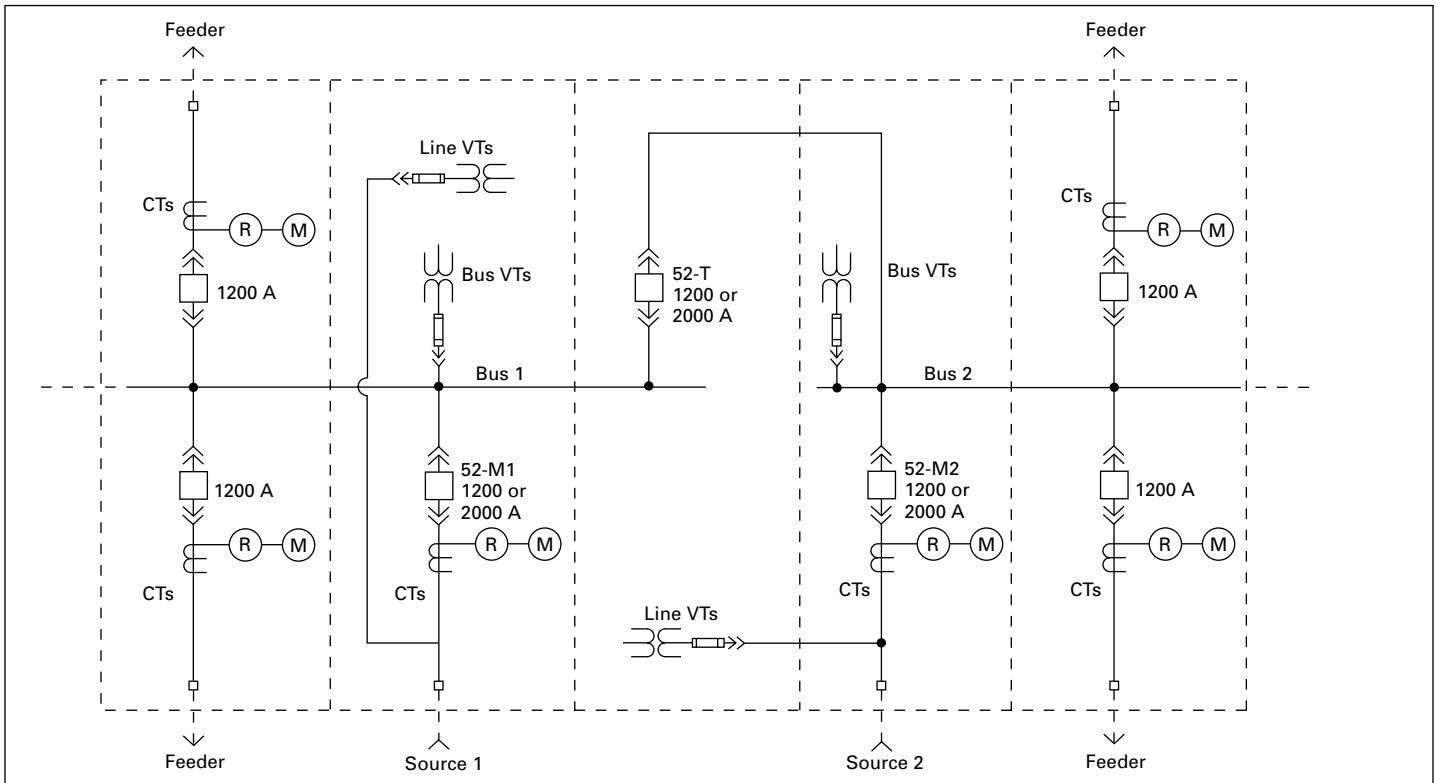

Figure 5.1-19. Typical Main-Tie-Main Arrangement with Bus and Line VTs, but without Line CPTs—Alternate Arrangement
 5 or 15 kV VCP-W Switchgear, 1200 or 2000 A Mains and Tie, 36.00-Inch (914.4 mm) Wide Structures

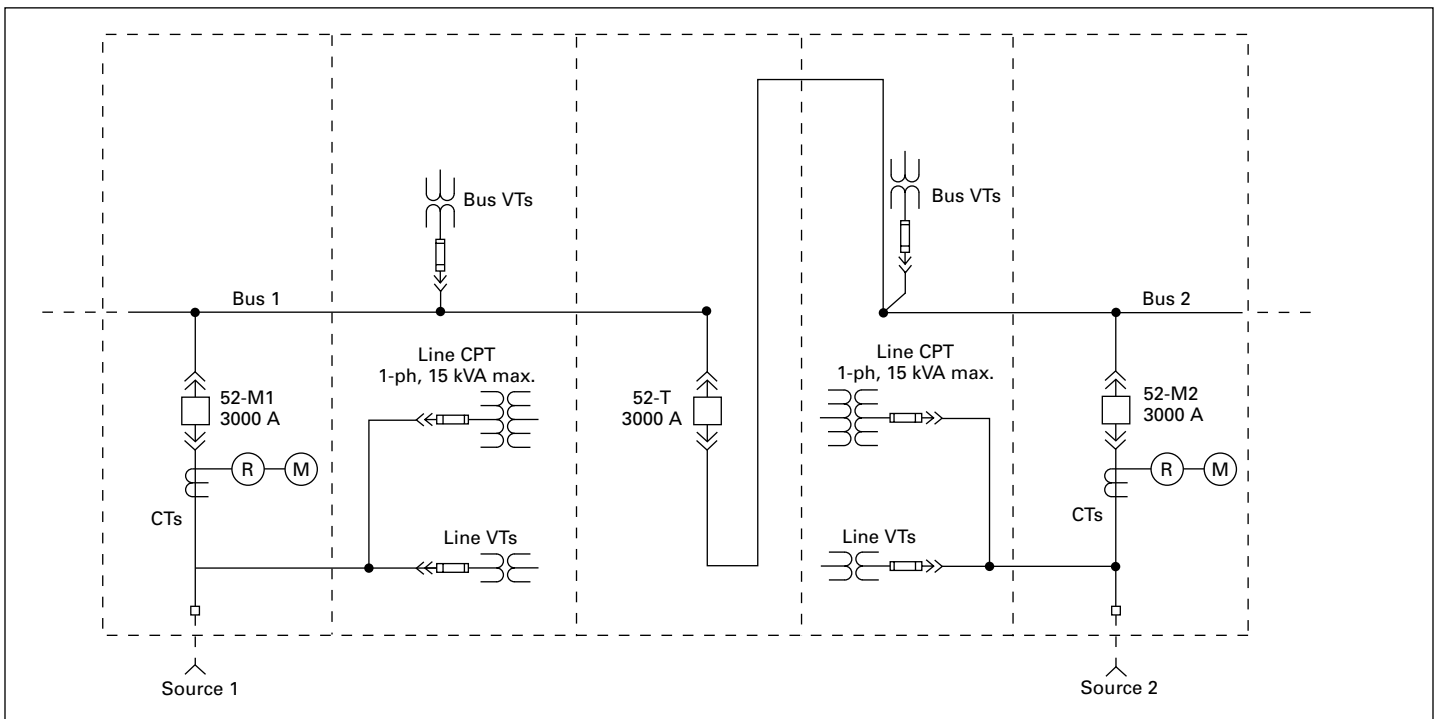

Figure 5.1-20. Typical Main-Tie-Main Arrangement with Bus and Line VTs, and Line CPTs
 5 or 15 kV VCP-W Switchgear, 3000 A Mains and Tie, 36.00-Inch (914.4 mm) Wide Structures

Typical Main-Tie-Main Arrangements (Continued)

Note: R = Multi-function relay, M = Multi-function meter

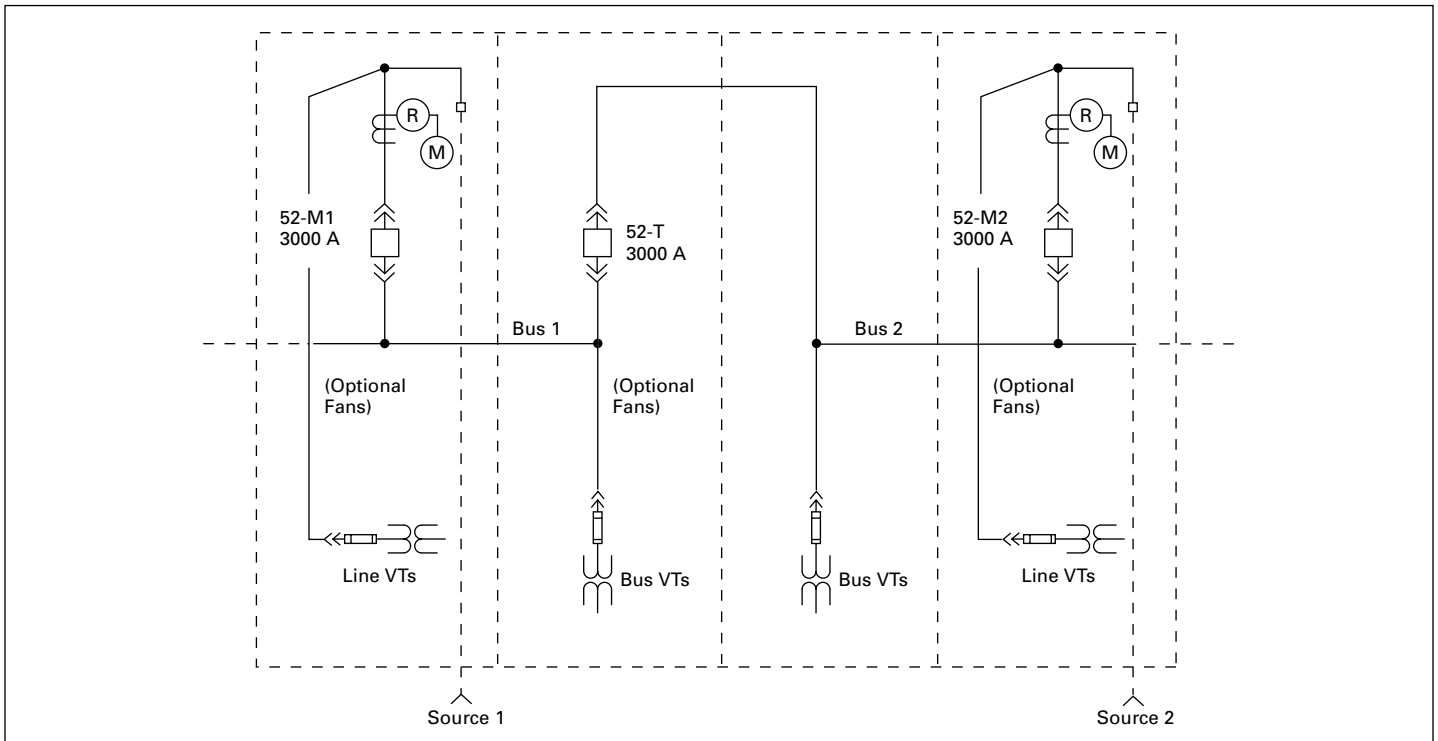

Figure 5.1-21. Typical Main-Tie-Main Arrangement with Bus and Line VTs 5 or 15 kV VCP-W Switchgear, 3000 A Mains and Tie, 36.00-Inch (914.4 mm) Wide Structures

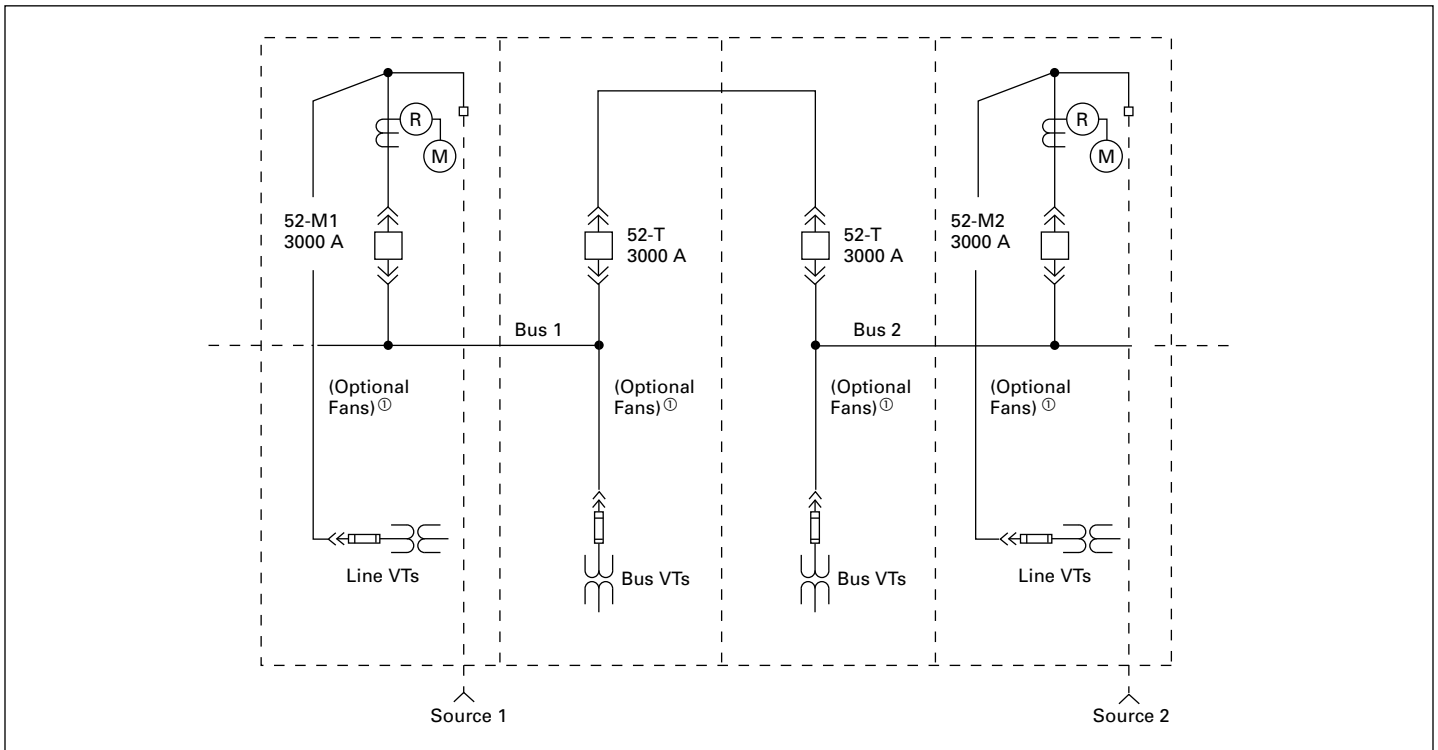

Figure 5.1-22. Typical Main-Tie-Main Arrangement with Bus and Line VTs 5 or 15 kV VCP-W Switchgear, 3000 A Mains and Tie, 36.00-Inch (914.4 mm) Wide Structures

① This arrangement can be supplied with cooling fans to allow 4000 A continuous.

Dimensions in Inches (mm)

Note: Dimensions for estimating purposes only.

Tie Breaker Bus Transition Requirements

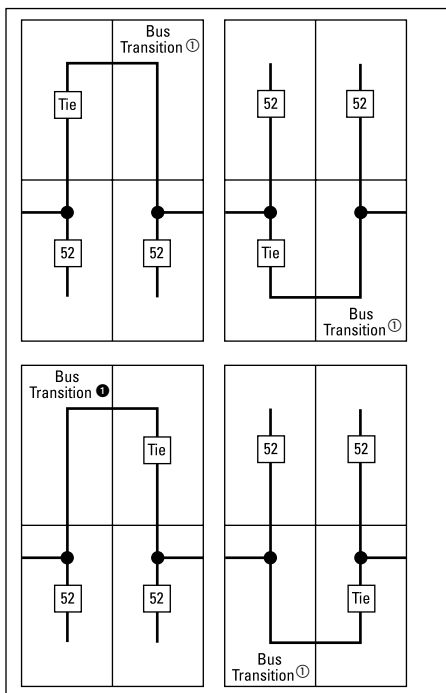

Figure 5.1-23. Tie Breaker Bus Transition Requirements

① Breakers cannot be located in bus transition compartment.

Available Configurations

1200 Ampere Breaker	1200 Ampere Breaker ^②	1200 Ampere Breaker
1200 Ampere Breaker	2000 Ampere Breaker ^②	Drawout Auxiliary
		Drawout Auxiliary
Drawout Auxiliary	2000 Ampere Breaker	Drawout Auxiliary
Drawout Auxiliary		Drawout Auxiliary
1200 Ampere Breaker	Drawout Auxiliary	2000 Ampere Breaker
	Drawout Auxiliary	
Blank (Ventilation)	Drawout Auxiliary	2000 Ampere Breaker ^②
	Drawout Auxiliary	
3000 Ampere Breaker	Drawout Auxiliary	1200 Ampere Breaker ^②
	Drawout Auxiliary	
3000 Ampere Breaker ^{③④}		
Vent Area		
Drawout Auxiliary		

Figure 5.1-24. Available Configurations

- ② Maximum 2500 A per structure for any combination of 2000 A and 1200 A.
- ③ For 4000 A force cooled application, refer to Eaton.
- ④ This configuration is available for indoor and outdoor walk-in designs only.

**Standard Height—
 Dimensions in Inches (mm)**

Note: Dimensions for estimating purposes only.

Typical Units

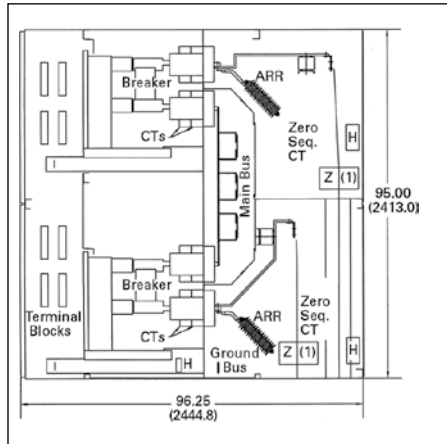

Figure 5.1-25. 36.00-Inch (914.4 mm) Wide Typical Breaker/Breaker Vertical Section

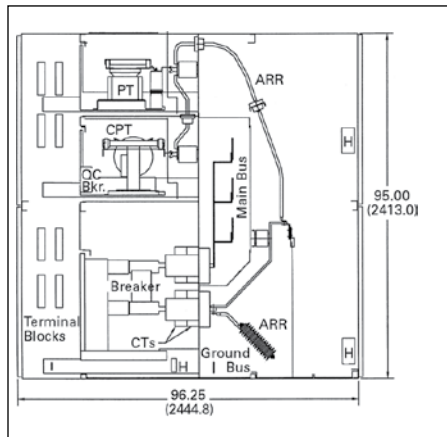

Figure 5.1-26. 36.00-Inch (914.4 mm) Wide Typical Auxiliary/Breaker Vertical Section

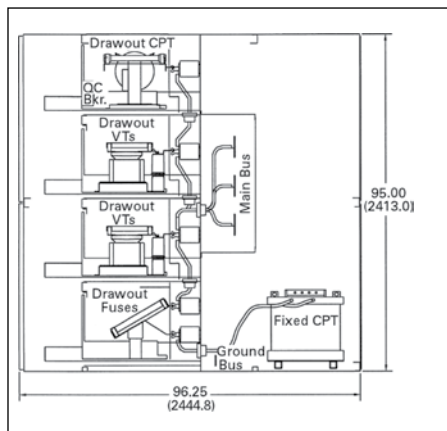

Figure 5.1-27. 36.00-Inch (914.4 mm) Wide Typical Auxiliary/Auxiliary Vertical Section

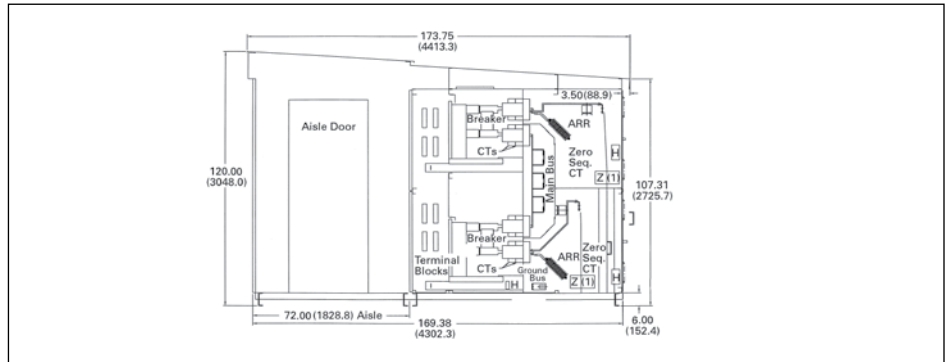

Figure 5.1-28. Outdoor Sheltered Aisle Single Row

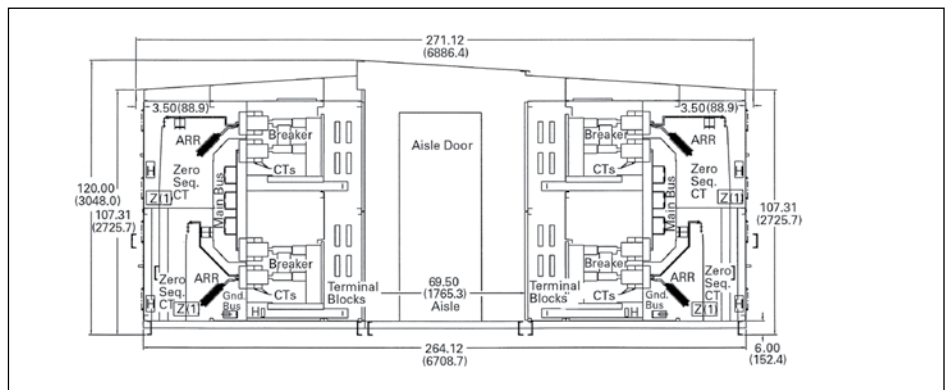

Figure 5.1-29. Outdoor Sheltered Aisle Double Row

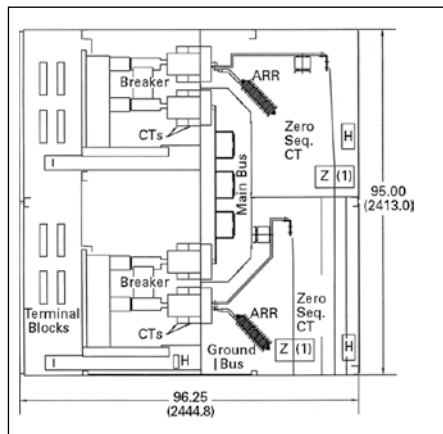

Figure 5.1-30. Indoor

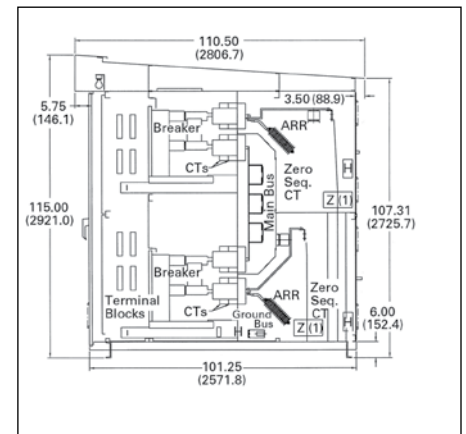

Figure 5.1-31. Outdoor Aisleless

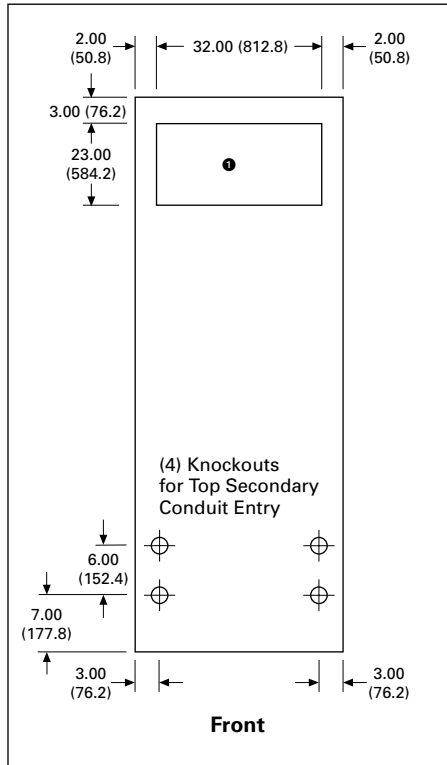

Figure 5.1-32. Top View of Typical Indoor Breaker and Auxiliary Structures

① Power cable entrance area. Refer to **Figure 5.1-34** for typical conduit locations. Refer to shop drawings for order specific locations.

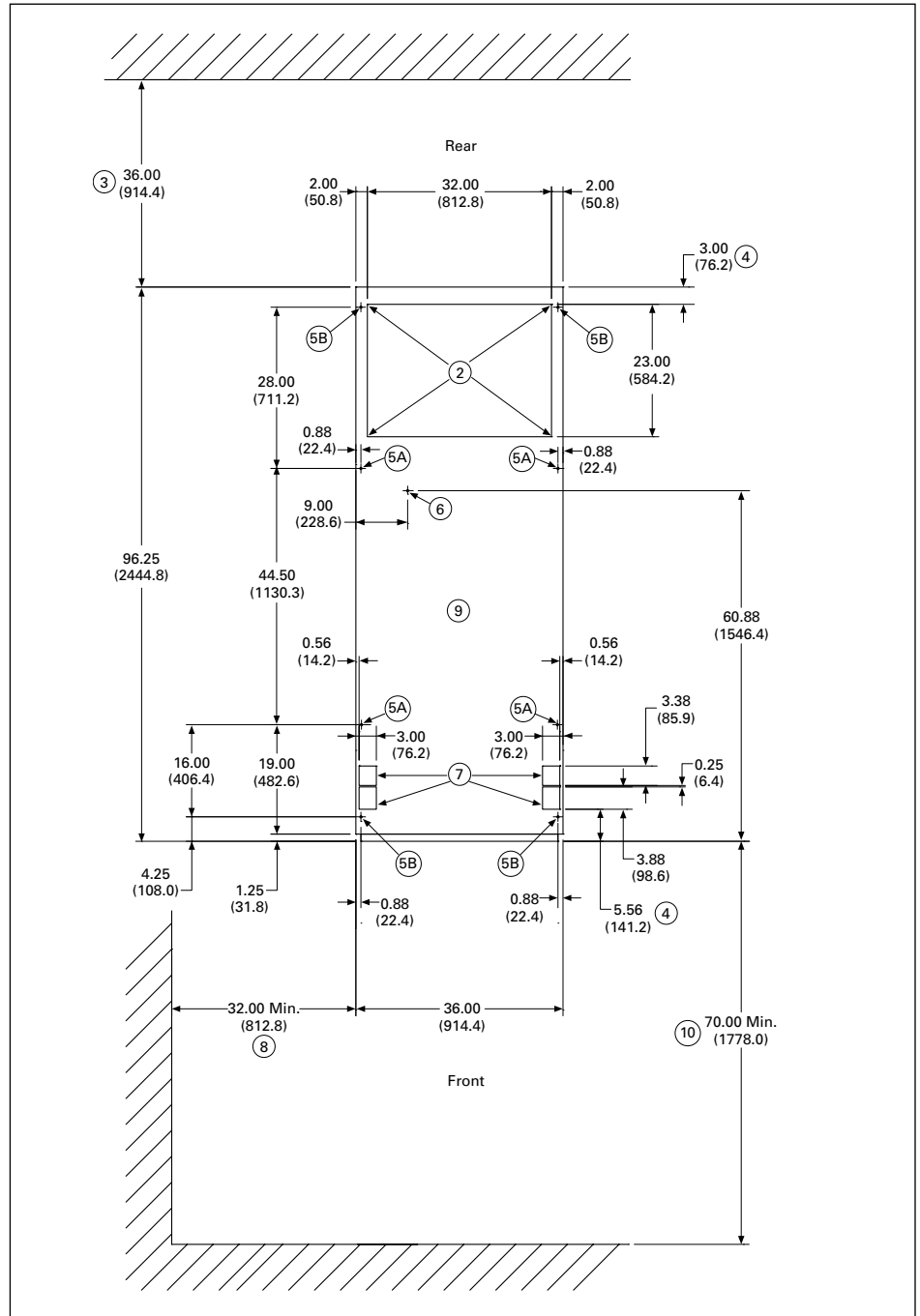

Figure 5.1-33. Base Plan of a Typical Indoor Breaker or Auxiliary Structure

- ② Power cable entrance area. Refer to **Figure 5.1-34** for typical conduit locations. Refer to shop drawings for order specific locations.
- ③ Recommended minimum clearance to rear of VacClad-W. Local authority having jurisdiction may require larger distance.
- ④ Floor steel, if used, must not exceed this dimension under VacClad-W.
- ⑤ Anchor locations: 5A and 5B for seismic applications, 5A only for non-seismic application. For indoor, use 0.5-inch (12.7 mm) bolts or weld.
- ⑥ Station ground connection provision.
- ⑦ Secondary conduit space: All—maximum of 1.00-inch (25.4 mm) projection.
- ⑧ Minimum clearance to LH side of VacClad-W. Minimum clearance to RH side of the switchgear: 6.00 inches (152.4 mm).
- ⑨ Finished foundation surface shall be level within 0.06-inch (1.5 mm) in 36.00 inches (914.4 mm) left-to-right, front-to-back, and diagonally, as measured by a laser level.
- ⑩ Minimum clearance to front of VacClad-W. Local authority having jurisdiction may require larger distance.

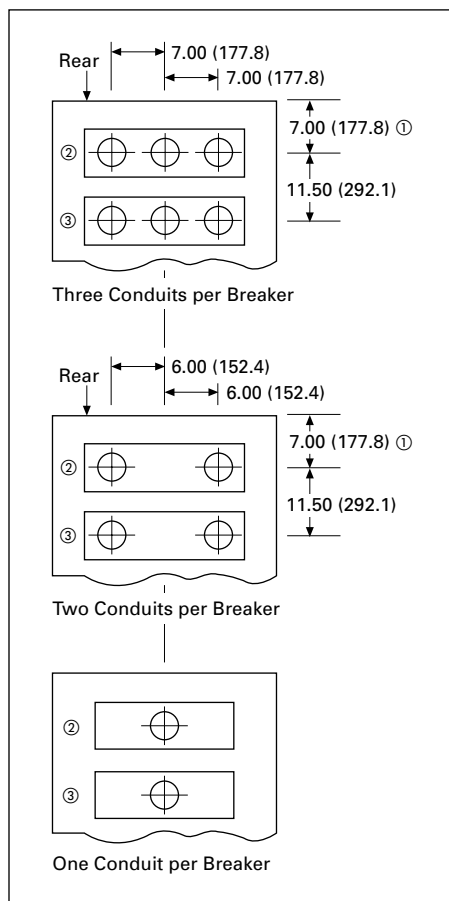

Figure 5.1-34. Primary Conduit Locations for 2-High Breakers ④⑤

- ① Changes to 8.25 (209.6 mm) if optional hinged rear doors are required.
- ② When cables enter from top, they connect to the breaker located in the bottom compartment. When cables enter from bottom, they connect to the breaker in the upper compartment.
- ③ When cables enter from top, they connect to the breaker located in the upper compartment. When cables enter from bottom, they connect to the breaker in the bottom compartment.
- ④ Contact Eaton for applications requiring more than three conduits per breaker.
- ⑤ It is the end user and/or the end user's designated third party responsibility to supply and install necessary sealing materials to ensure penetrations made after shipment are properly sealed and weatherproofed to maintain the integrity of the switchgear.

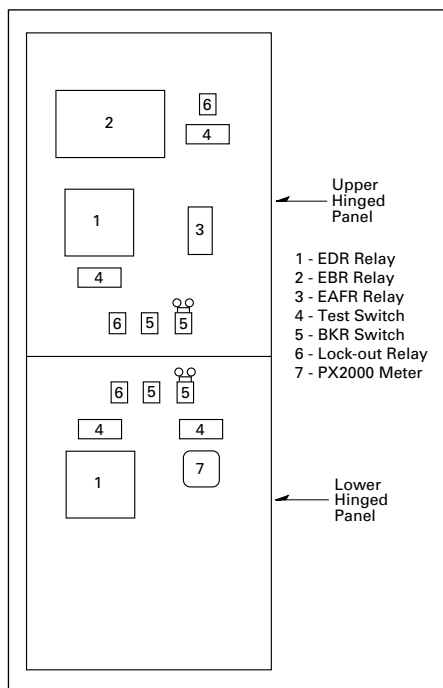

Figure 5.1-35. Maximum Hinged Panel Equipment

Note: The figure above shows that the arrangement of components differs between upper and lower panels. The figure may also be used to select custom arrangements of hinged panel components. Also, the use of multi-function relays such as Eaton's E-series relays will significantly reduce consumption of panel space.

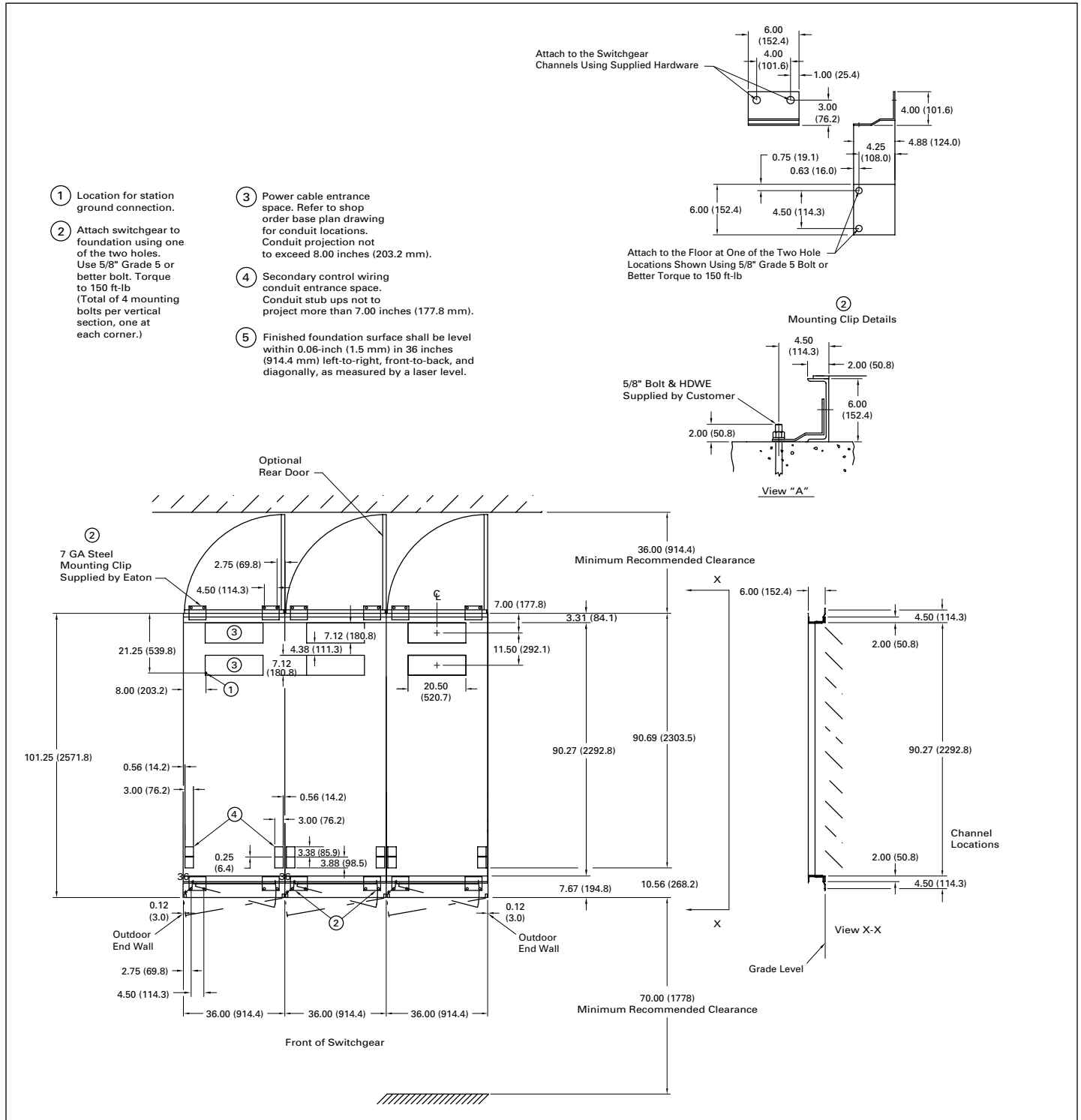

Figure 5.1-36. 5/15 kV Switchgear Outdoor Aisleless Base Plan (Typical Details)—Dimensions in Inches (mm)

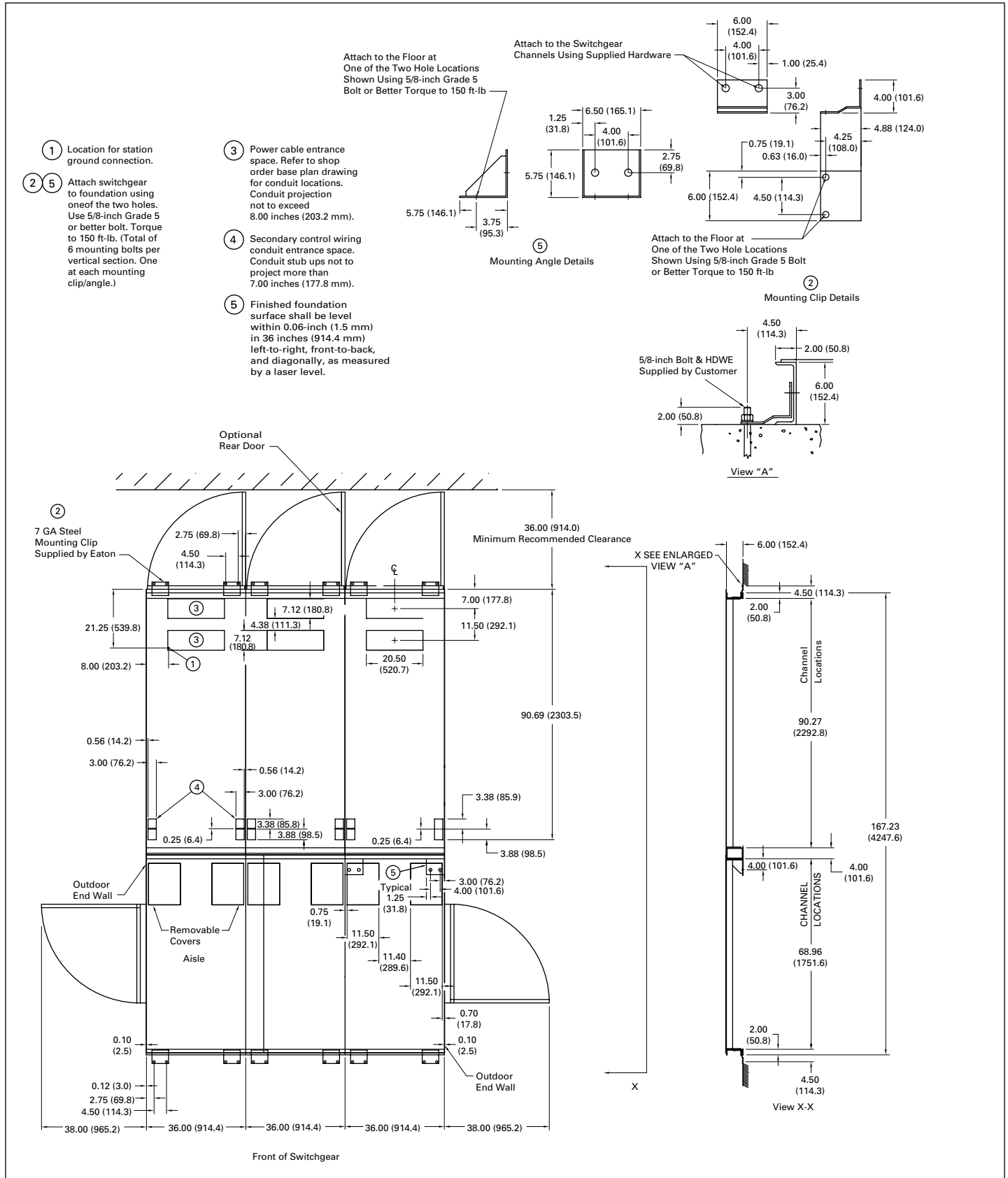

Figure 5.1-37. 5/15 kV Switchgear Outdoor Sheltered Aisle Base Plan (Typical Details)—Dimensions in Inches (mm)

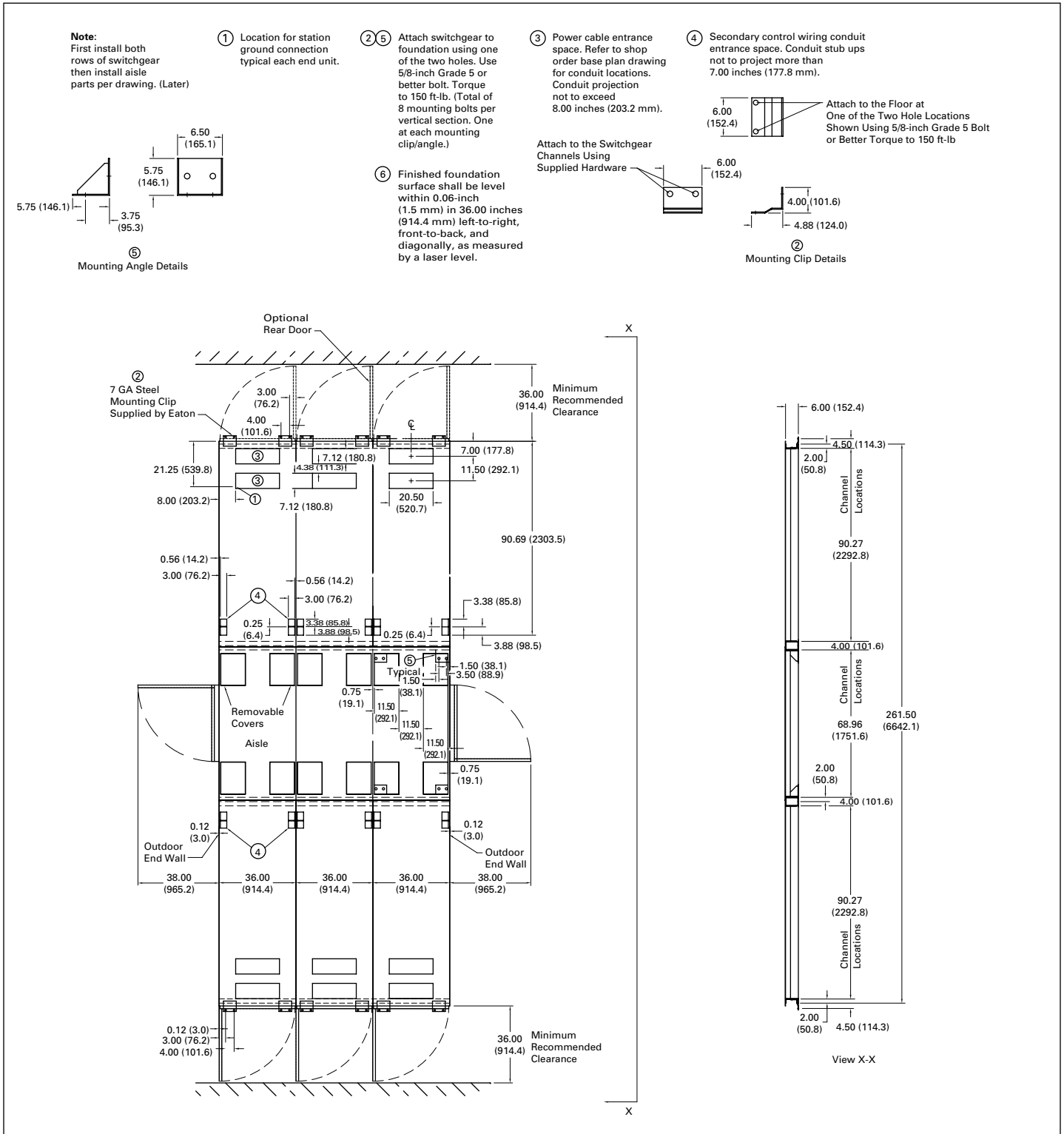

Figure 5.1-38. 5/15 kV Switchgear Outdoor Common Aisle Base Plan (Typical Details)—Dimensions in Inches (mm)

Low Profile—Dimensions

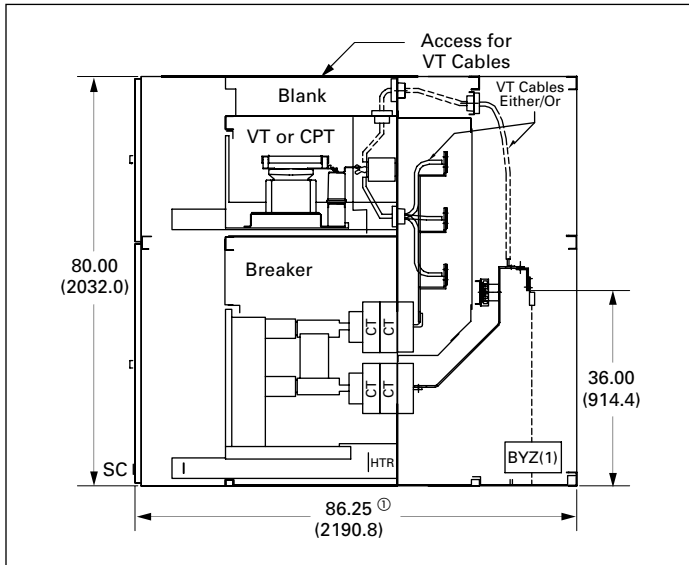

Figure 5.1-39. 36.00-Inch (660.4 mm) Wide VCP-W Low Profile Indoor Unit

① Other depths possible depending on cable entry direction and VT/CPT connections. Contact Eaton.

Low Profile—Layouts

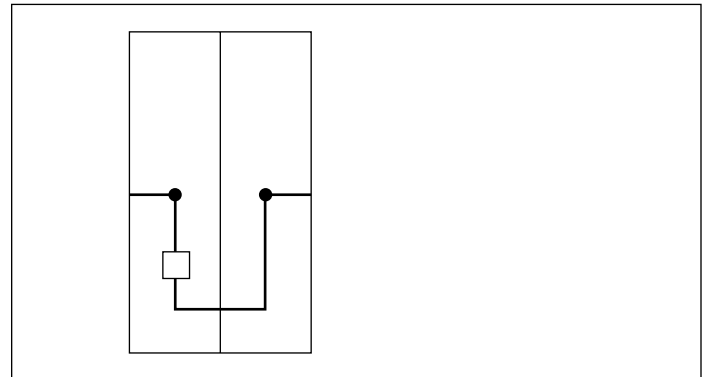

Figure 5.1-40. Tie Breaker Bus Transition Requirements

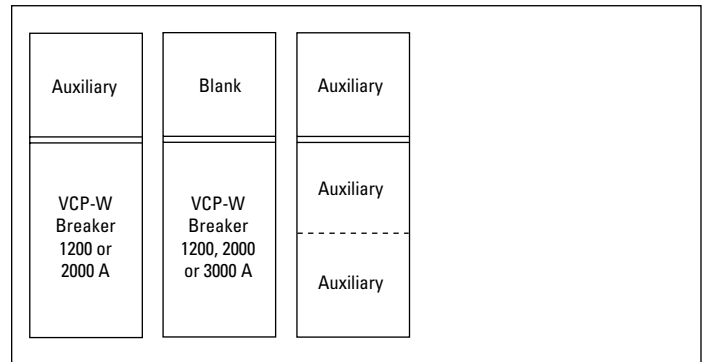

Figure 5.1-41. Available Configurations (Front View)

Service Conditions

Usual Service Conditions

Usual service conditions for operation of metal-clad switchgear are as follows:

- Altitude does not exceed 3300 feet (1000 m)
- Ambient temperature within the limits of –30 °C and +40 °C (–22 °F and +104 °F)
- The effect of solar radiation is not significant

Applications Above 3300 Feet (1006 m)

Equipment utilizing sealed interrupting devices (such as vacuum interrupters) does not require derating of rated maximum voltage. The rated one-minute power frequency withstand voltage, the impulse withstand voltage and the continuous current rating must be multiplied by the appropriate correction factor in **Table 5.1-15** to obtain modified ratings that must equal or exceed the application requirements.

Note: Intermediate values may be obtained by interpolation.

Applications Above or Below 40 °C Ambient

Refer to ANSI C37.20.2, Section 8.4 for load current-carrying capabilities under various conditions of ambient temperature and load.

Unusual Service Conditions

Applications of metal-clad switchgear at other than usual altitude or temperature, or where solar radiation is significant, require special consideration. Other unusual service conditions that may affect design and application include:

- Exposure to salt air, hot or humid climate, excessive dust, dripping water, falling dirt, or other similar conditions
- Unusual transportation or storage conditions
- Switchgear assemblies when used as the service disconnecting means
- Installations accessible to the general public
- Exposure to seismic shock
- Exposure to nuclear radiation

Applications at Frequencies Less Than 60 Hz

Rated Short-Circuit Current

Based on series of actual tests performed on Type VCP-W circuit breakers and analysis of these test data and physics of vacuum interrupters, it has been found that the current interruption limit for Type VCP-W circuit breakers is proportional to the square root of the frequency. **Table 5.1-13** provides derating factors, which must be applied to breaker interrupting current at various frequencies.

Table 5.1-13. Derating Factors

Interrupting Current Derating Factors			
50 Hz ①	25 Hz	16 Hz	12 Hz
None	0.65	0.52	0.45

① For 50 Hz application data, apply to all VCP-W, -WC and -WG circuit breakers except those included in **Table 5.1-2**.

Rated Short-Time and Close and Latch Currents

No derating is required for short time and close and latch current at lower frequency.

Rated Continuous Current

Because the effective resistance of circuit conductors is less at lower frequency, continuous current through the circuit can be increased somewhat. **Table 5.1-14** provides nominal current rating for VCP-W breakers when operated at frequencies below 60 Hz.

Table 5.1-14. Current Ratings

Rated Continuous Current at 60 Hz	Nominal Current at Frequency Below 60 Hz			
	50 Hz ②	25 Hz	16 Hz	12 Hz
1200 A	1243	1410	1519	1589
2000 A	2075	2374	2573	2703
3000 A	3119	3597	3923	4139

② For 50 Hz application data, apply to all VCP-W, -WC and -WG circuit breakers except those included in **Table 5.1-2**.

Power Frequency and Impulse Withstand Voltage Ratings

No derating is required for lower frequency.

CTs, VTs, Relays and Instruments

Application at frequency other than rated frequency must be verified for each device on an individual basis.

Table 5.1-15. Altitude Derating Factors

Altitude Above Sea Level in Feet (m)	Altitude Correction Factor to be Applied to:	
	Voltage	Rated Continuous Current
3300 (1006) (and Below)	1.0	1.0
4000 (1219)	0.98	0.995
5000 (1524)	0.95	0.991
6000 (1829)	0.92	0.987
6600 (2012)	0.91	0.985
7000 (2137)	0.89	0.98
8000 (2438)	0.86	0.97
9000 (2743)	0.83	0.965
10,000 (3048)	0.80	0.96
12,000 (3658)	0.75	0.95
13,200 (4023)	0.72	0.94
14,000 (4267)	0.70	0.935
16,000 (4877)	0.65	0.925
16,400 (5000)	0.64	0.92
18,000 (5486)	0.61	0.91
20,000 (6096)	0.56	0.90

Standard Height—Weights

Typical Weights in Lb (kg)

Table 5.1-16. Assemblies (Less Breakers. See Table 5.1-17 for Breakers.)

Vertical Section Type	Main Bus Rating Amperes	Indoor	Aisleless	Sheltered-Aisle Including Aisle	
				Single Row	Double Row
B/B	1200	3550 (1610)	4350 (1973)	5350 (2427)	8350 (3787)
	2000	3650 (1656)	4450 (2018)	5450 (2472)	8550 (3878)
	3000	3750 (1701)	4550 (2064)	5550 (2517)	8750 (3969)
	4000 ①	3275 (1486)	4075 (1848)	5075 (2302)	8275 (3753)
B/A or A/B	1200	3450 (1565)	4050 (1837)	5250 (2381)	8150 (3697)
	2000	3550 (1610)	4150 (1882)	5350 (2427)	8350 (3787)
	3000	3650 (1656)	4250 (1928)	5450 (2472)	8550 (3878)
	4000 ①	3175 (1440)	3775 (1712)	4975 (2257)	8075 (3663)
A/A	1200	2700 (1225)	3300 (1497)	4500 (2041)	7100 (3221)
	2000	2800 (1270)	3400 (1542)	4600 (2087)	7300 (3311)
	3000	2900 (1315)	3500 (1588)	4700 (2132)	7500 (3402)
	4000	3000 (1361)	3600 (1633)	4800 (2177)	7600 (3447)

① 4000 A offering only available with a single breaker per structure only (no auxiliary allowed).

Table 5.1-17. Breaker Weights in Lb (kg)

Breaker Type	Current Rating, Amperes		
	1200	2000	3000
	Approximate Weight, Lb (kg), Static ②		
5 VCP-W 25, 40, 50 15 VCP-W 25, 40, 50	374 (170) 374 (170)	374 (170) 374 (170)	426 (193) 426 (193)
50 VCP-W 250, 25, 40 50 VCP-W 350, 40C, 50C, 50, 63C 50 VCP-W 500, 63	350 (159) 460 (209) 575 (261)	410 (186) 490 (222) 575 (261)	525 (238) 525 (238) 575 (261)
75 VCP-W 500, 50C, 50 150 VCP-W 500, 25C, 25 150 VCP-W 750, 40	375 (170) 350 (159) 350 (159)	410 (186) 490 (222) 410 (186)	525 (238) 525 (238) 525 (238)
150 VCP-W 1000, 40C, 50C, 50, 63C 150 VCP-W 1500, 63	460 (209) 575 (261)	490 (222) 575 (261)	525 (238) 575 (261)

② Impact weight = 1.5 times static weight.

Low Profile—Weights

Typical Weights in Lb (kg)

Table 5.1-18. Assemblies (Less Breakers. See Table 5.1-17 for Breakers)

Vertical Section Type	Main Bus Rating, Amperes	Indoor Structure
B/B	1200	2200 (999)
	2000	2300 (1044)
	3000	2400 (1090)
B/A or A/B	1200	2100 (953)
	2000	2200 (999)
	3000	2300 (1044)
A/A	1200	1800 (818)
	2000	1900 (864)
	3000	2000 (908)

Heat Loss

Table 5.1-19. Heat Loss in Watts at Full Rating, at 60 Hz

Type of Switchgear Assembly	Breaker Rating	1200 A	2000 A	2500 A	3000 A	4000 A Fan Cooled
VCP-W	5, 15	600W	1400W	—	2100W	3700W

Other Components

Each CT, standard accuracy	50 W
Each CT, high accuracy	100 W
Each VT	60 W
CPT single-phase, 25 kVA	450 W
CPT single-phase, 45 kVA	892 W
Space heater—each	250 W

Control Power Requirements

Table 5.1-20. VCP-W Breaker Stored Energy Mechanism Control Power Requirements

Rated Control Voltage	Spring Charging Motor			Close or Trip Amperes	UV Trip mA Maximum	Voltage Range		Indicating Light Amperes
	Inrush Amperes	Run Amperes	Average Run Time, Sec.			Close	Trip	
48Vdc	36.0	9	6	16	200	38–56	28–56	0.02
125Vdc	16.0	4	6	7	80	100–140	70–140	0.02
250Vdc	9.2	2	6	4	40	200–280	140–280	0.02
120Vac	16.0	4	6	6	—	104–127	104–127	0.02
240Vac	9.2	2	6	3	—	208–254	208–254	0.02

Table 5.1-21. Control Power Transformers—Single-Phase, 60 Hz ①

Rated Primary Voltage, Volt	Rated Secondary Voltage, Volt	kVA	kV Class
2400	240–120	5, 10, 15	5
4160	240–120	5, 10, 15	5
4800	240–120	5, 10, 15	5
7200	240–120	5, 10, 15	15
8400	240–120	5, 10, 15	15
12470	240–120	5, 10, 15	15
13200	240–120	5, 10, 15	15
13800	240–120	5, 10, 15	15

① Line-to-line connection only available. Refer to Eaton for other voltages and kVA ratings.

Typical Schematics

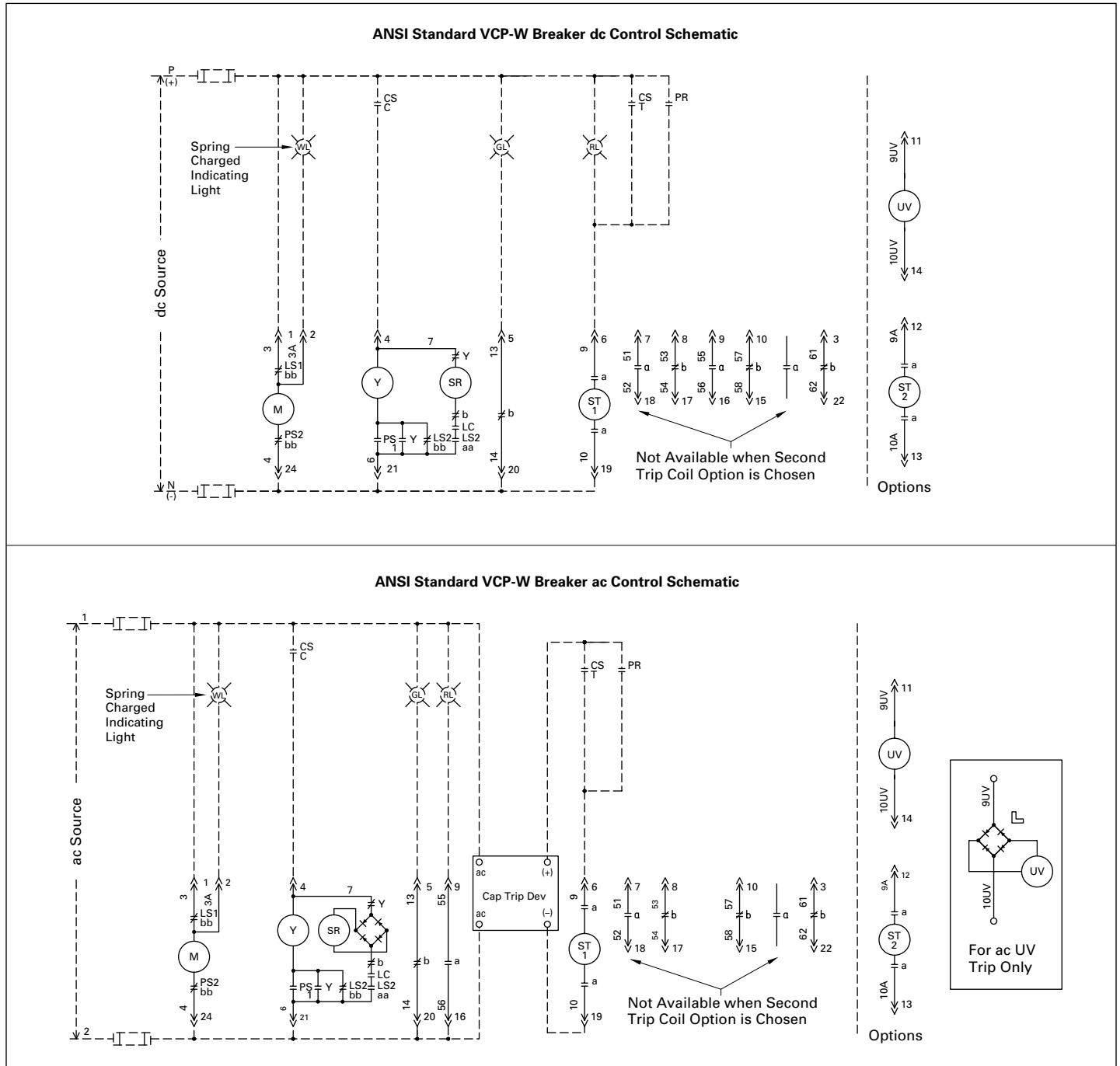
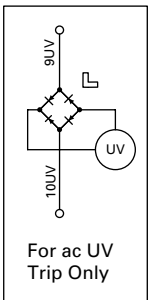

Figure 5.1-42. Typical 5/15/27 kV VCP-W “dc” and “ac” Control Schematics

Legend: CS = Breaker Control Switch–Close
 C = Breaker Control Switch–Close
 CS = Breaker Control Switch–Trip
 T = Breaker Control Switch–Trip
 Y = Anti Pump Relay
 SR = Spring Release Coil (Coil)
 M = Spring Charge Motor
 ST = Shunt Trip
 PR = Protective Relay
 ^ = Secondary Disconnect

Operation: LS1 = Closed until springs are fully charged.
 bb = Closed until springs are fully charged.
 LS2 = Open until springs are fully charged.
 aa = Open until springs are fully charged.
 LS2 = Closed until springs are fully charged.
 bb = Closed until springs are fully charged.
 LC = Open until mechanism is reset.
 PS1 = Open in all except between “Test” and “Connected” positions.
 PS2 = Closed in all except between “Test” and “Connected” positions.



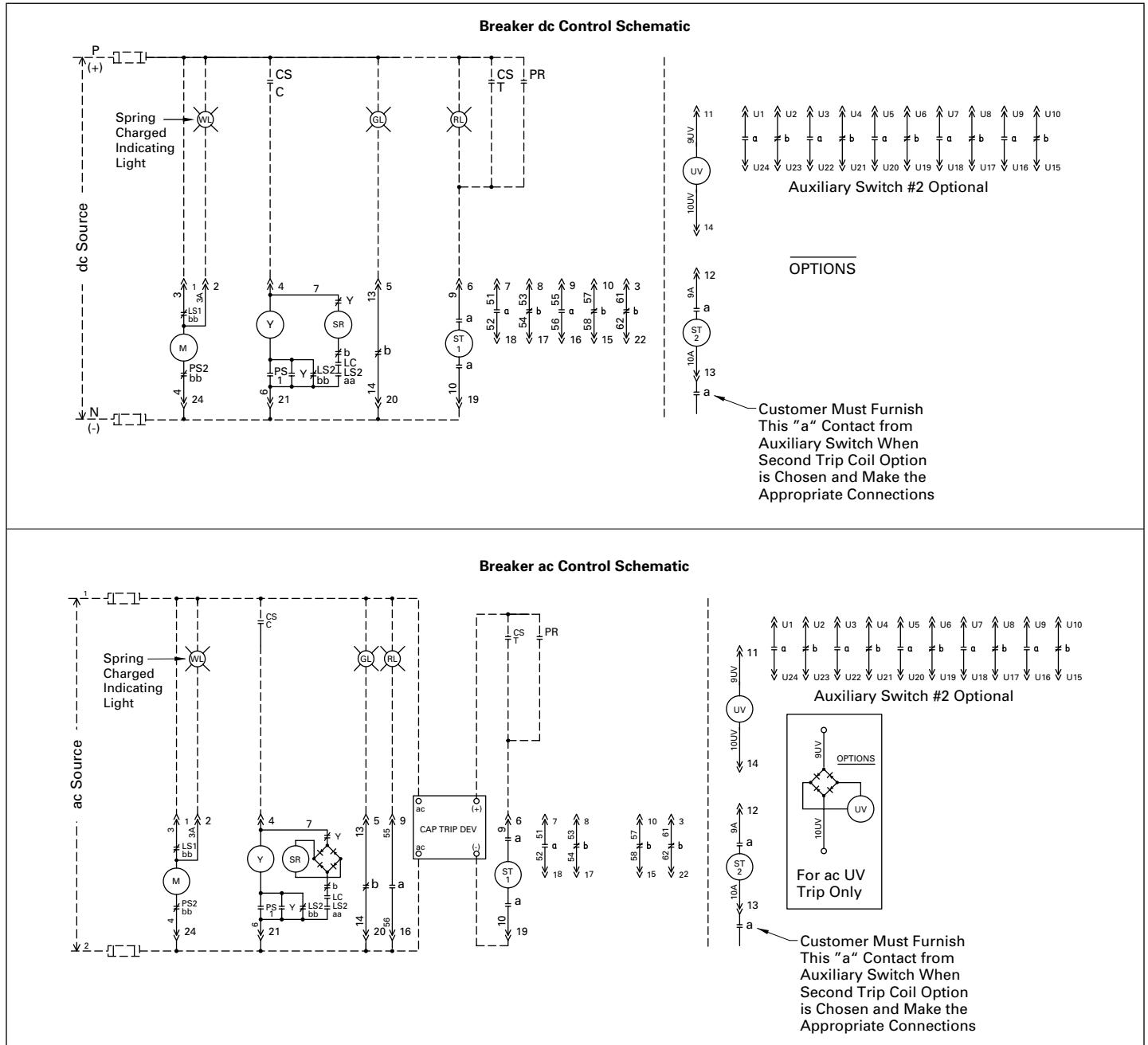

Figure 5.1-43. Typical 38 kV VCP-W "dc" and "ac" Control Schematics

Legend: CS = Breaker Control Switch–Close
 C = Breaker Control Switch–Close
 CS = Breaker Control Switch–Trip
 T = Breaker Control Switch–Trip
 Y = Anti Pump Relay
 SR = Spring Release Coil (Coil)
 M = Spring Charge Motor
 ST = Shunt Trip
 PR = Protective Relay
 ^ = Secondary Disconnect

Operation: LS1 = Closed until springs are fully charged.
 bb = Closed until springs are fully charged.
 LS2 = Open until springs are fully charged.
 aa = Open until springs are fully charged.
 LS2 = Closed until springs are fully charged.
 bb = Closed until springs are fully charged.
 LC = Open until mechanism is reset.
 PS1 = Open in all except between "Test" and "Connected" positions.
 PS2 = Closed in all except between "Test" and "Connected" positions.

Eaton
1000 Eaton Boulevard
Cleveland, OH 44122
United States
Eaton.com

© 2022 Eaton
All Rights Reserved
Printed in USA
Publication No. DG022001EN / Z27094
December 2022

Eaton is a registered trademark.

All other trademarks are property
of their respective owners.